

Sonalert® Audible Signal Devices

Series	Mounting	Frequency ±500 Hz	Voltage Range (VDC)	Loudness (dB)	Current (mA)	Tone	Page
Commercial and Industrial							
SC	Classic Panel (Screw Neck)	1900 - 4500	1 - 250 (AC&DC)	50 - 95	1 - 28	Various	3 - 5
SBM	P.C. Board	2900	1 - 28	55 - 78	3 - 16	Various	
SNP	Panel (Snap-In)	2900	4 - 28	55 - 76	3 - 18	Various	
SC	Classic Panel (Screw Neck)	1750/3000	6 - 16	60 - 72	2 - 27	<u>Multi-Tone</u> WY = 3 Mode WXY = 5 Mode	6
LSC	Classic Panel (Screw Neck)	2900 (Audible)	6 - 250 (AC&DC)	80 - 96	4 - 60	Continuous with Pulsing Red LED	7
VSB	Classic Panel (Screw Neck)	800&1200-2000	Cross Walk 110/120 (VAC)	80	30	<u>Multi-Tone</u> Cuckoo Chirp	8
MSR MSO	Printed Circuit Board	3400 - 3900 (15mm Pitch)	3 - 20	75 - 86	3 - 16	Contiuous & Pulse	9 - 10
Sonalert® for Military Applications							
SC	Classic Panel (Screw Neck)	1900/4500	6 - 250 (AC&DC)	60 - 95	3 - 26	Various	14
Sonalert® Accessories							
SCMB	— Electrical Mounting Box						17
RSB1	— Vinyl Terminal Insulating Boot						
SCVC	— Manual Volume Control						
BNR1	— Anodized Black Aluminum Mounting Nut (Standard on Military units)						
CNR1	— Anodized Clear Aluminum Mounting Nut						
PNR1	— Black Plastic (Nylon 6/6) Mounting Nut (Standard on Commercial and Industrial units)						
SG1	— Sonalert Gasket to aid in sealing NEMA applications						
PW	— Compression Washers for Case Style B						15
BP6	— Bakelite Mounting Wafer						
MP6	— Metal Mounting Wafer						
Case Styles							15 - 16
Technical Information on Sound							12
Environmental Specifications							11
Other Audible Signals							
Mounted Piezo Transducers							18
Indicators							23
Transducer & Indicator Outline Drawings							21 - 22
Piezo Transducers - External Drive (No Feedback)							19
Piezo Transducers - Self Drive (With Feedback)							19
Electro-Magnetic Transducers							20
Telephone Ringers							20
Piezo Indicators							24 - 25
Electro-Magnetic Indicators							26
Piezo Sirens							26
Piezo Siren Outline Drawings							27
Miniature Speakers (Cone Type)							20

**Most items in this catalog are in inventory and available for immediate shipment.
Contact Sales Service for availability.**

Introduction

Sonalert® Audible Signal Devices

MALLORY



The Mallory Sonalert® produces an audible tone by internally creating an oscillating signal which drives a piezo ceramic transducer mounted in a sound chamber. Various types of continuous and intermittent tones are available from the Mallory Sonalert® product line.

Self driven piezo ceramic transducers are superior to electromagnetic buzzers because they produce no arcing, electrical noise, or mechanical wear during operation. They are more reliable and operate more consistently during their operating life and are able to produce many more types of tones compared to buzzers.

The Mallory Sonalert® can be actuated by AC and DC power signals and has several mounting configurations and terminations available.

Criteria for Selecting Mallory Sonalert® Products

There are a multitude of Sonalert® models listed in this catalog. The following factors should be considered before selecting a Sonalert® from the list of models available:

- 1. Continuous or Intermittent tone?**
Intermittent tones are more discernable than continuous tones.
- 2. Magnitude of sound required?**
Loud, medium, and soft sounds are available for many versions.
- 3. What type of actuation signal is available?**
Sonalerts are available in various AC and DC voltages from 1V to 250V.
- 4. What type of mounting configuration and termination is required?**
Many types are available and outlined on the next few pages.
- 5. Can't find exactly what you require?**
Contact the Sonalert® Engineering Department to see if a custom design can be produced for your application. Special continuous and intermittent tones can be created for your unique application. Special mounting configurations and terminations can also be developed.

Because the operation of the Sonalert® audible signal device is dependent upon the circuit in which it is used, it is advisable to thoroughly test the selected device in the specific circuit and application to assure mechanical and electrical compatibility and verify system performance.

Specifications are subject to change without notice.

Underwriters Laboratories

The following models are listed as recognized components - Audible Signal Appliances

SC628 and models with suffixes A, AD, AJ, AN, ANJ, ANP, AP, D, DJ, DP, H, HJ, HP, J, L, N, NL, P, -9B.
SC648 and models with suffixes A, AD, AJ, AN, AP, D, S.
SC110 and models with suffixes CP, D, DJ, DP, H, J, K, N, NJ, NP, P, Q.
SC616 and models with suffixes CP, CPN, NJ, NL, NP, N.
SC250 and models with suffixes D, J, N, P.
VSB110-1, VSB110-1L, VSB110-2, VSB110-2L
SBM2, SBM428.
SC105, SC307N, SC416, SNP428

Guide Number UCST2, Yellow Card Number S1290.

Mallory Sonalerts are covered by one or more of the following U.S. Patent Numbers:
5,675,311 - 5,675,312 - 5,793,282 - 5,872,506 - 5,990,784 - 6,130,618 - 6,310,540

Commercial and Industrial Sonalert® Audible Signal Devices



Catalog Number	Loudness Category	Mounting Method	Case Style	Frequency ± 500 Hz	Minimum Sound Pressure dB (A) at Two Feet		Operating Voltage * AC/DC Non-Polar All Others DC Only		Operating Current (mA)	
					At Min V	At Max V	■ Min	Max	At Min V	At Max V
Continuous Tones										
• SC110N	Loud	Panel	D	2900	80	95	* 30	*120	6	24
• SC250N	Loud	Panel	D	2900	80	90	* 60	*250	5	18
• SC307N	Loud	Panel	C	2900	80	90	3	7	3	9
• SC616N	Loud	Panel	C	2900	80	95	6	16	6	22
• SC616NL	Loud	Panel	C-3	2900	80	95	6	16	6	22
• SC628N	Loud	Panel	C	2900	80	90	6	28	6	23
• SC628ND	Loud	Panel	D	2000 ±300	75	95	6	28	3	15
SC616N-3	Loud	Printed Board	G	2900	80	95	6	16	6	22
• SC628NL	Loud	Panel	C-3	2900	80	90	6	28	6	23
• SC628AN	Loud	Panel	D	2900	80	95	* 6	* 28	4	30
• SC648AN	Loud	Panel	D	2900	80	95	* 10	* 48	4	26
SC648ND	Loud	Panel	D	1900 ±300	80	90	10	48	6	22
• SBM2	Medium	Printed Board	F	2900	55	68	1	5	3	16
• SBM428	Medium	Printed Board	F	2900	64	78	4	28	3	16
SNP2	Medium	Snap In Panel	B	2900	55	68	1	5	3	12
• SNP428	Medium	Snap In Panel	B	2900	64	76	4	28	3	18
• SC105	Medium	Panel	C	2900	60	75	1	5	3	16
• SC110	Medium	Panel	D	2900	68	80	* 30	*120	6	21
• SC110D	Medium	Panel	D	1900	60	75	* 30	*120	6	21
• SC110H	Medium	Panel	D	4500	68	80	* 30	*120	6	21
• SC250	Medium	Panel	D	2900	68	80	* 60	*250	5	18
• SC250D	Medium	Panel	D	1900	60	72	* 60	*250	5	16
SC250H	Medium	Panel	D	4500	68	80	* 60	*250	5	16
• SC416	Medium	Panel	C	2900	68	80	4	16	4	14
• SC628	Medium	Panel	C	2900	68	80	6	28	3	18
• SC628A	Medium	Panel	D	2900	68	80	* 6	* 28	6	23
• SC628AD	Medium	Panel	D	1900	60	75	* 6	* 28	6	23
SC628AH	Medium	Panel	D	4500	68	80	* 6	* 28	4	16
• SC628D	Medium	Panel	C	1900 ±300	60	75	6	28	6	23
• SC628H	Medium	Panel	C	4500	68	80	6	28	6	23
• SC628L	Medium	Panel	C-3	2900	68	80	6	28	6	23
▲ST628	Medium	Panel	C	2900	60	80	6	28	3	14
• SC648	Medium	Panel	C	2900	68	80	10	48	5	22
• SC648A	Medium	Panel	D	2900	68	80	* 10	* 48	4	16
• SC648AD	Medium	Panel	D	1900	60	75	* 10	* 48	4	16
SC648AH	Medium	Panel	D	4500	68	80	* 10	* 48	4	16
• SC648D	Medium	Panel	C	1900	60	75	10	48	6	23
SC648H	Medium	Panel	C	4500	68	80	10	48	4	16
SC1.5	Soft	Twist Tab	A	3500	60@1.5V		1	4	4@ 1.5V	
SC6	Soft	Twist Tab	A	3500	68@ 6V		4	8	12@ 6V	
SC12	Soft	Twist Tab	A	3500	70@ 12V		8	15	14@ 12V	
SC18	Soft	Twist Tab	A	3500	70@ 18V		14	20	16@ 18V	
SC24	Soft	Twist Tab	A	3500	70@ 24V		20	30	16@ 24V	
SNP428F	Soft	Snap In Panel	B	2900	52	68	4	28	0.5	3
SC110E	Soft	Panel	D	1900	55	65	* 30	*120	4	14
SC110F	Soft	Panel	D	2900	55	65	* 30	*120	2	6
SC250E	Soft	Panel	D	1900	55	65	* 60	*250	5	16
SC250F	Soft	Panel	D	2900	55	65	* 60	*250	2	6
SC628AE	Soft	Panel	D	1900	50	65	* 6	* 28	3	14
SC628AF	Soft	Panel	D	2900	50	65	* 6	* 28	2	6
SC628E	Soft	Panel	C	1900	55	68	6	28	3	11
SC628F	Soft	Panel	C	2900	55	70	6	28	2	4
SC648AE	Soft	Panel	D	1900	55	65	* 10	* 48	3	12

▲ Denotes High Trigger Model (Start Up Voltage Approximately 3 V).

* For AC Operation (AC Voltage is RMS for 50 or 60 Hz Power Line)

■ Minimum voltage specified for sound test does not represent sound turn-on or turn-off points. Units will sound at lower voltages.

• Denotes UL Models

Commercial and Industrial Sonalert® Audible Signal Devices



Catalog Number	Loudness Category	Mounting Method	Case Style	Frequency ± 500 Hz	Minimum Sound Pressure dB (A) at Two Feet		Operating Voltage * AC/DC Non-Polar All Others DC Only		Typical Operating Current (mA)	
					At Min V	At Max V	■ Min	Max	At Min V	At Max V

Short Pulse

Turns on and off at .5 to 2 pulses per second depending upon voltage at 10% duty cycle.

• SC110K	Medium	Panel	E	2900	68	80	* 30	* 120	6	22
SC250K	Medium	Panel	E	2900	68	80	* 60	* 250	5	18
SC628K	Medium	Panel	D	2900	68	80	6	28	6	23
SC628AK	Medium	Panel	E	2900	68	80	* 6	* 28	4	16
SC648AK	Medium	Panel	E	2900	68	80	* 10	* 48	4	16
SC110FK	Soft	Panel	E	2900	55	65	* 30	* 120	4	16
SC250FK	Soft	Panel	E	2900	52	65	* 60	* 250	4	16
SC628FK	Soft	Panel	D	2900	50	65	6	28	4	14
SC628AFK	Soft	Panel	E	2900	50	70	* 6	* 28	3	14

Catalog Number	Loudness Category	Mounting Method	Case Style	Frequency ± 500 Hz	Minimum Sound Pressure dB (A) at Two Feet		Operating Voltage * AC/DC Non-Polar All Others DC Only		Typical Operating Current (mA)	
					At Min V	At Max V	■ Min	Max	At Min V	At Max V

Intermittent Tones

Fast Pulse (1)	Slow Pulse (2)										
• SC110NP	• SC110NJ	Loud	Panel	D	2900	80	95	* 30	* 120	8	24
• SC616NP	• SC616NJ	Loud	Panel	C	2900	80	95	6	16	6	22
▶ SC616NP-10	—	Loud	Panel	D-4	2900	80	95	6	16	6	18
SC628NP	SC628NJ	Loud	Panel	D	2900	80	90	6	28	4	16
SC628NDP	—	Loud	Panel	D	2000 ±300	85	95	10	28	3	16
• SC628ANP	• SC628ANJ	Loud	Panel	D	2900	80	95	* 6	* 28	4	30
SC648ANP	SC648ANJ	Loud	Panel	D	2900	80	95	* 10	* 48	4	26
SBM616P	SBM616J	Medium	Printed Board	F	2900	68	78	6	16	3	12
• SC110DP	• SC110DJ	Medium	Panel	E	1900	60	75	* 30	* 120	6	20
SC110HP	SC110HJ	Medium	Panel	E	4500	68	80	* 30	* 120	6	20
• SC110P	• SC110J	Medium	Panel	E	2900	68	80	* 30	* 120	6	22
SC250DP	SC250DJ	Medium	Panel	E	1900	60	72	* 60	* 250	5	16
SC250HP	SC250HJ	Medium	Panel	E	4500	68	80	* 60	* 250	5	16
• SC250P	• SC250J	Medium	Panel	E	2900	68	78	* 60	* 250	4	16
SNP616P	SNP616J	Medium	Snap In Panel	B-1	2900	65	75	6	16	3	8
SC616P	SC616J	Medium	Panel	C-1	2900	68	78	6	16	2	9
SC616P-1	SC616J-1	Medium	Panel	C-11	2900	68	78	6	16	2	9
SC628ADP	SC628ADJ	Medium	Panel	E	1900 ±300	60	75	* 6	* 28	6	20
SC628AHP	SC628AHJ	Medium	Panel	E	4500	68	80	* 6	* 28	4	16
• SC628AP	• SC628AJ	Medium	Panel	E	2900	68	80	* 6	* 28	4	16
• SC628DP	• SC628DJ	Medium	Panel	D	1900 ±300	60	75	6	28	6	16
• SC628HP	• SC628HJ	Medium	Panel	D	4500	68	80	6	28	4	16
• SC628P	• SC628J	Medium	Panel	D	2900	68	80	6	28	6	26
SC648ADP	SC648ADJ	Medium	Panel	E	1900	60	75	* 10	* 48	4	20
• SC648AP	• SC648AJ	Medium	Panel	E	2900	68	80	* 10	* 48	6	21
SC110EP	SC110EJ	Soft	Panel	E	1900	55	65	* 30	* 120	4	14
SC110FP	SC110FJ	Soft	Panel	E	2900	55	65	* 30	* 120	4	16
SC250EP	SC250EJ	Soft	Panel	E	1900	55	68	* 60	* 250	5	16
SC250FP	SC250FJ	Soft	Panel	E	2900	55	65	* 60	* 250	4	16
SC628AEP	SC628AEJ	Soft	Panel	E	1900 ±300	50	65	* 6	* 28	4	16
SC628AFP	SC628AFJ	Soft	Panel	E	2900	50	65	* 6	* 28	4	12
SC628EP	SC628EJ	Soft	Panel	D	1900 ±300	50	65	6	28	3	14
SC628FP	SC628FJ	Soft	Panel	D	2900	50	65	6	28	3	14

(1) Turns on and off at 2 to 10 pulses per second depending upon voltage at 50% duty cycle.

(2) Turns on and off at .5 to 2 pulses per second depending upon voltage at 50% duty cycle.

▶ Pulse rate 2 to 10 pps with 10 second shutoff
• Denotes UL Models

* For AC Operation
(AC Voltage is RMS for 50 or 60 Hz Power Line)

■ Minimum voltage specified for sound test does not represent sound turn-on or turn-off points. Units will sound at lower voltages.

Commercial and Industrial Sonalert® Audible Signal Devices



Catalog Number	Loudness Category	Mounting Method	Case Style	Frequency ± 500 Hz	Minimum Sound Pressure dB (A) at Two Feet		Operating Voltage * AC/DC Non-Polar All Others DC Only		Typical Operating Current (mA)		
					At Min V	At Max V	■ Min	Max	At Min V	At Max V	
Dual Mode Operation											
Continuous or Fast Pulse (1)		Continuous or Slow Pulse (2)		When power terminals are connected, third terminal may be switched to open to select a continuous sound or switched to positive (+) to select a pulsing sound. Switching current is less than 2.0 milliamp.							
SC616NPU	---	Loud	Panel	D-1	2900	80	90	6	16	6	26
SBM616PU	SBM616JU	Medium	Printed Board	F	2900	68	78	6	16	3	12
SC616PU	SC616JU	Medium	Panel	C-7	2900	68	78	6	16	3	12
▶ SC616PU-1	▶ SC616JU-1	Medium	Panel	C-7	2900	68	80	6	16	2	12
---	▶ SC628JU-1	Medium	Panel	C-7	2900	68	80	6	28	3	25

▶ Has two negative hook-ups

Fast Warble (1)		Slow Warble (2)		Warble							
(+) Single package warbler. Pulse rate is 1.5pps (typical) @ 50% duty cycle.											
---	(+) SC110JW	Medium	Panel	D	1800-2800	68	80	* 30	*120	6	26
---	(+) SC616JW	Medium	Panel	C	1800-2800	68	80	6	16	6	26
---	(+) SC630JW	Medium	Panel	D	1800-2800	68	80	6	30	6	35
The following models must be used with SC628D or SC628H. Warble will then consist of two tones alternately.											
SC628W	SC628JW	Medium	Panel	D-1	2900	68	80	6	28	4	20
The following models must be used with with SC628E. Warble will then consist of two tones alternately.											
SC628FW	SC628FJW	Soft	Panel	D-1	2900	55	70	6	28	2	8

- (1) Turns on and off at 2 to 10 pulses per second depending upon voltage at 50% duty cycle.
 (2) Turns on and off at .5 to 2 pulses per second depending upon voltage at 50% duty cycle.

Chime Tone											
A pleasant sound which chimes every one or two seconds as long as voltage is applied. Pulse rate is 0.3 to 2 pps at 50% duty cycle.											
• SC110CP	Medium	Panel	E	2900	68	78	* 30	*120	6	22	
SC628CPN	Loud	Panel	C	2900	76	86	6	28	6	16	
SC628CPNL	Loud	Panel	C-3	2900	76	86	6	28	6	16	
• SC616CP	Medium	Panel	D	2900	68	78	6	16	6	23	
• SC616CPN	Loud	Panel	D	2900	76	86	6	16	6	23	

Chirp											
A unique sound which pulses at 20 to 60 pps.											
• SC110Q (AC Only)	Medium	Panel	C	2900	68	80	30 AC	120 AC	6	22	
SC616Q	Medium	Panel	C-1	2900	68	78	6	16	3	12	

Siren Tone											
• SC648S	Loud	Panel	D	1900-2900	80	90	10	48	38	80	
Sweep rate @ 5Hz (typical) ±1.5Hz				± 300 Hz							

• Denotes UL Models

* For AC Operation
(AC Voltage is RMS for 50 or 60 Hz Power Line)

■ Minimum voltage specified for sound test does not represent sound turn-on or turn-off points. Units will sound at lower voltages.

Multi-Tone Sonalert® Audible Signal Devices

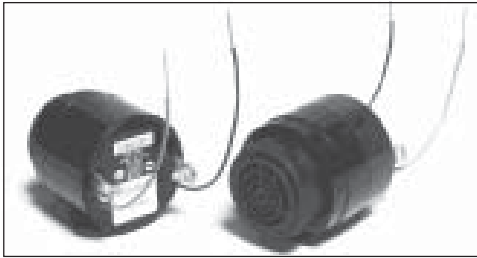

Models SC616WY & SC616WXY

Key Features

The Multi-Tone Sonalert models SC616WY and SC616WXY are piezoelectric signaling devices with several functions. When operated and controlled from a 6-16 VDC source, they produce distinctive tone patterns. The SC616WY tone patterns are: pulsate high frequency, pulsate low frequency and warble. The SC616WXY has two additional tones - continuous high and low frequency. Operating modes are determined by the connection of two control wires.

The Multi-Tone Sonalert employs all solid state circuitry. When driven at the maximum supply voltage, a sound pressure of 72 dB at 2 feet is obtained. Both models have a low current drain (27 mA max).

Mechanical

Outline drawing and dimensions - See below.

Case Material: Nylon
 Mounting method: Panel
 Terminals: .032 brass, tin plated, tapped for #6-32 screw.
 Two #6-32 nickel plated brass screws included.

Will accept 1/4" quick disconnect terminals (non-standard).

Control wire size: 24AWG, stranded, 6" long

Operating temperature: -30°C to +65°C

Control Functions

The red and black leads control the several functions. A logic "Low" is a voltage less than 1/3 of supply voltage. A logic "High" is a voltage greater than 1/2 supply voltage. A red or black input lead left unconnected is considered an open state.

Typical Performance

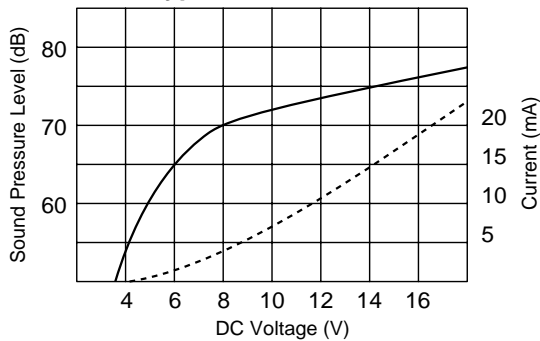

Dimensions

(Case Style D-2)

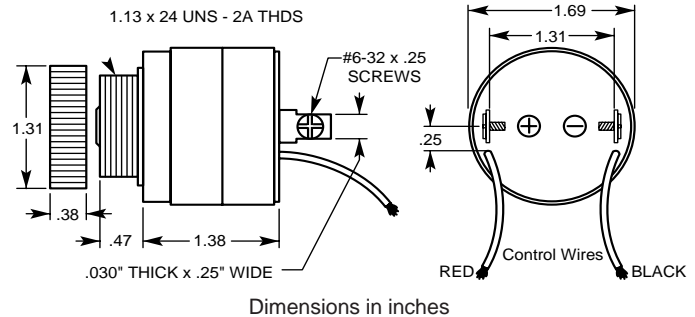

Electrical

Catalog Number	Voltage		Maximum Current mA		High Tone Frequency ± 500	Low Tone Frequency ± 500	Pulse Rate Per Second @ 50% Duty Cycle	Minimum Sound Pressure dB at Two Feet	
	Min.	Max.	At Min. V	At Max. V				At Min. V	At Max. V
SC616WY	6	16	6	27	3000	1750	.5 - 1.2	60	72
SC616WXY	6	16	6	27	3000	1750	.5 - 1.2	60	72

* 50% Duty Cycle

Truth Table for SC616WY

Control Lead		Function Mode
Red	Black	
Low	Low	Off
High	Low	High Pulse
Low	High	Low Pulse
High	High	Warble

Truth Table for SC616WXY

Control Lead		Function Mode
Red	Black	
High	Low	Off
Open	High	High Continuous
Open	Low	Low Continuous
High	Open	High Pulse
Low	Open	Low Pulse
Open	Open	Warble

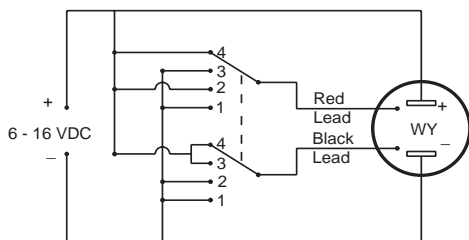

Schematics: Set to Warble

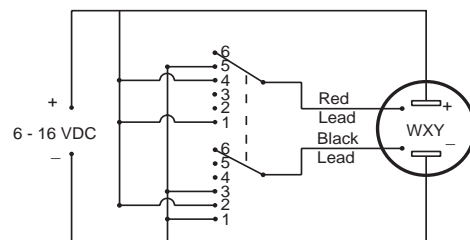

Type LSC Sonalert® Optical/Audible Signal Devices



- Made in USA
- Panel Mounting
- Flashing Ultra Bright Red LED Indicator
- Loud Continuous Tone
- 3-Way Terminals
- Environmentally Sealed

GENERAL SPECIFICATION

LED Pulse Rate: 2 ± 1.5 pps
 LED View Angle: Wide 80°
 Resonant Frequency: 2900 ± 500 Hz
 Operating Temperature: -30°C to $+65^\circ\text{C}$
 Storage Temperature: -40°C to $+85^\circ\text{C}$
 Case Material: Black Nylon 6/6

APPLICATIONS

Control Panels
 Industrial Equipment
 Medical Equipment
 Home, Office, Auto, Fire and Security
 Alarms
 Call Buzzers
 Multi-Alarm Identification

Catalog Number	Rated Voltage	Source Voltage Type	Minimum Sound Pressure dB (A) at Two Feet		Maximum Operating Current (mA)		Typical Weight (Grams)
			At Min V	At Max V	At Min V	At Max V	
LSC616N	6 - 16	DC	80 @ 6	95 @ 16	40 @ 6	60 @ 16	42
LSC110N	30 - 120	AC/DC	88 @ 30	98 @ 120	5 @ 30	16 @ 120	59
LSC250N	60 - 250	AC/DC	84 @ 60	87 @ 250	4 @ 60	14 @ 250	59
LSC628AN	6 - 28	AC/DC	85 @ 6	95 @ 28	4 @ 6	48 @ 28	59

KEY FEATURES AND BENEFITS

The Mallory Optical Alerts feature a loud continuous tone with a flashing ultra bright LED indicator. These solid state devices also offer low current consumption, high reliability, and long life.

MARKET TRENDS AND FORECASTS

With safety and security requirements growing more stringent, the Mallory Optical Alerts are the obvious choice for applications that command immediate attention. The flashing red center light is used in conjunction with the audible signal to fortify the meaning of the signal. Understanding the potential of this market, Mallory Sonalert Products, Inc. is dedicated to manufacturing the highest quality audible signal devices, assuring customers they will experience high reliability with all Sonalert® products. The mission of Mallory Sonalert Products, Inc. is to design quality audible signal devices that meet or exceed customer and industry standards.

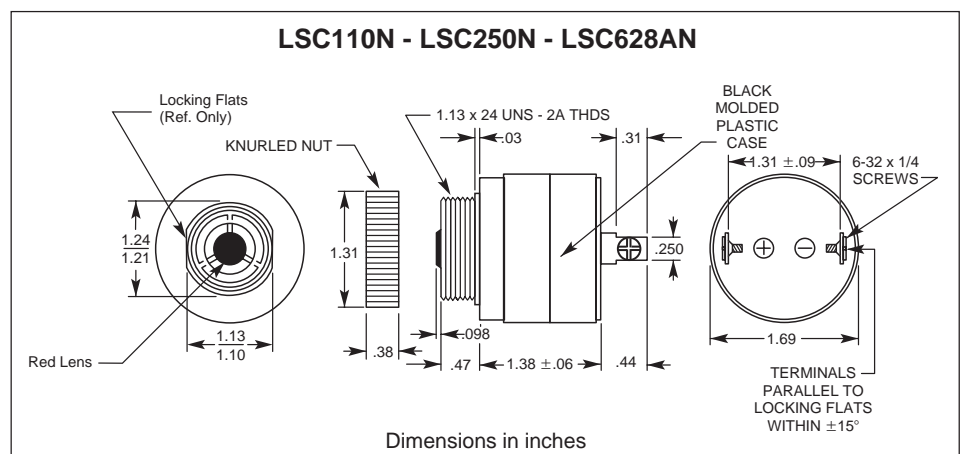
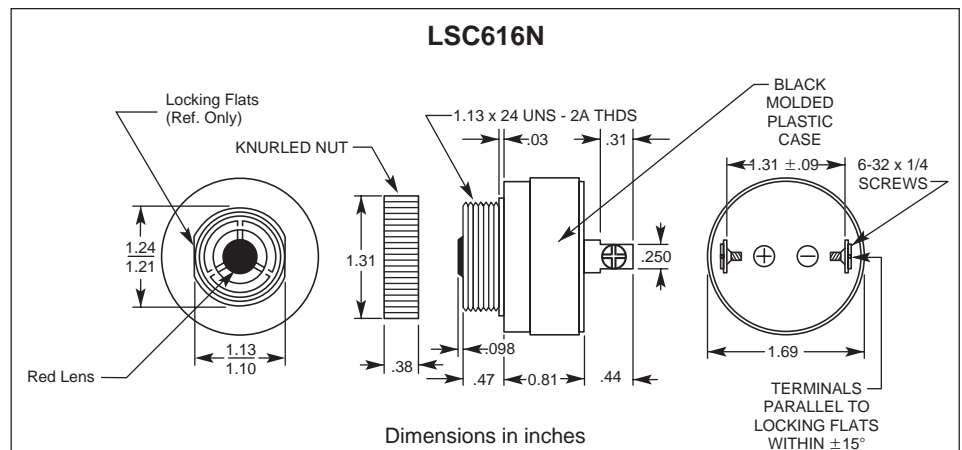

Type VSB Sonalert® Crosswalk Audible Signal Devices



- Made in USA
- Panel Mounting
- High-Quality Analog Record / Playback
- Bird Calls
- 3-Way Terminals
- Environmentally Sealed

GENERAL SPECIFICATIONS:

Resonant Frequency:.....800 & 1,200 Hz (Cuckoo)
2,000 Hz (Chirp)

Minimum Sound Pressure
@ 120 VAC, 60 Hz:.....80 db(A) @ 2ft.

Rated Voltage:.....110/120 VAC @ 60 Hz

Maximum Current:.....30 mA @ 120 VAC

Operating Temperature:.....-40°C to +85°C

Storage Temperature:.....-40°C to +85°C

APPLICATION

Audible Signal For Pedestrian Crosswalks

Characteristics

VSB110-1

Cuckoo (North - South)
800 Hz & 1,200 Hz
Repeats approximately every 1.5 seconds

VSB110-2

Chirp (East - West)
2,000 Hz
Repeats approximately every 1 second

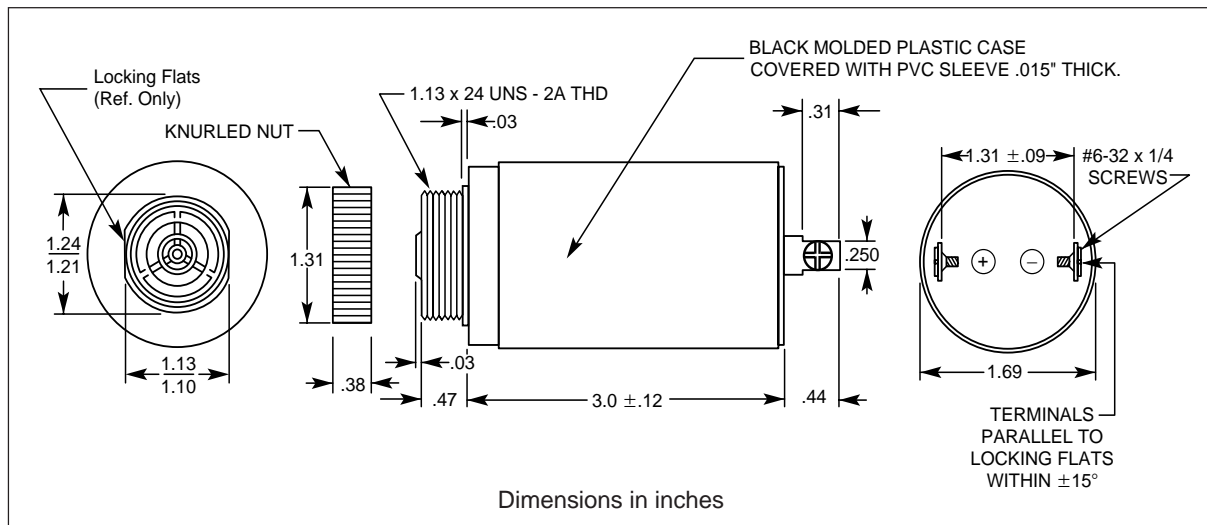

Optional Termination Style

Add an "L" to the end of the part number for 14", black, 22AWG wire leads.
Example: VSB110-1L

All models are U.L recognized.
File # 1290, Guide UCST2

Type MSR Sonalert® Audible Signal Devices - Extra Loud



- Made in USA
- Low Power Consumption
- Low Cost
- Compact Profile
- Piezo Tone Quality
- Wave Solderable
- Extra Loud Sound Output

GENERAL SPECIFICATION

Operating Temperature:
-20°C to +65°C

Storage Temperature:
-30°C to +80°C

Solder Temperature:
+270°C for 3 seconds

Case Material (Blue)
VALOX (UL94V-0)

Weight (Typical):
3.5 grams

APPLICATIONS

Fire Alarm
Crime Prevention Alarm
Call Buzzer
Automotive
Clocks
P.O.S. Equipment
Medical Instruments
Electrical Instruments

Catalog Number	Frequency ± 400Hz	Minimum Sound Pressure dB (A) @ Two Feet		Operating Voltage	Maximum Operating Current (mA)		Pulse Rate Per Second
		At Min. V	At Max. V		At Min. V	At Max. V	
MSR414N	3900	75	86	4 - 14	3	16	Continuous
MSR516N	3850	75	86	5 - 16	3	14	Continuous
MSR516NJ	3900	75	86	5 - 16	3	12	.5 - 2 (Slow)
MSR516NP	3900	75	86	5 - 16	3	12	2 - 10 (Fast)
MSR516X	3800 Avg.	75	86	5 - 16	3	12	2 - 4 (Siren) ①
MSR516W	3700 Avg.	75	86	5 - 16	3	12	5 - 7 (Whooping) ②

The devices shown are piezoelectric audible signal devices with a built-in oscillator circuit. All devices are suitable for wave soldering when ordered with the sound emission hole covered with a wash label. The recommended maximum temperature and exposure time for wave soldering is +270°C for 3 seconds. Optional wash label may be ordered by adding 'S' to model number. Example: MSR516NS

MSR516X & MSR516W Sound Output WaveForms

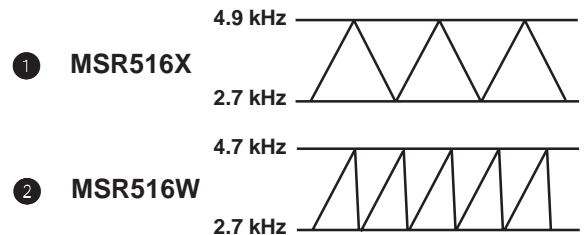

Shape and Dimensions (mm)

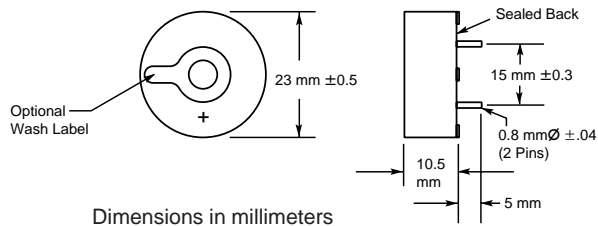

Typical Reference Conditions for Various Applications

Sound Pressure @ 12Vdc

100 dB(A) @ 10 cm	85 dB(A) @ 2 ft.
91 dB(A) @ 30 cm	82 dB(A) @ 100 cm

Characteristics

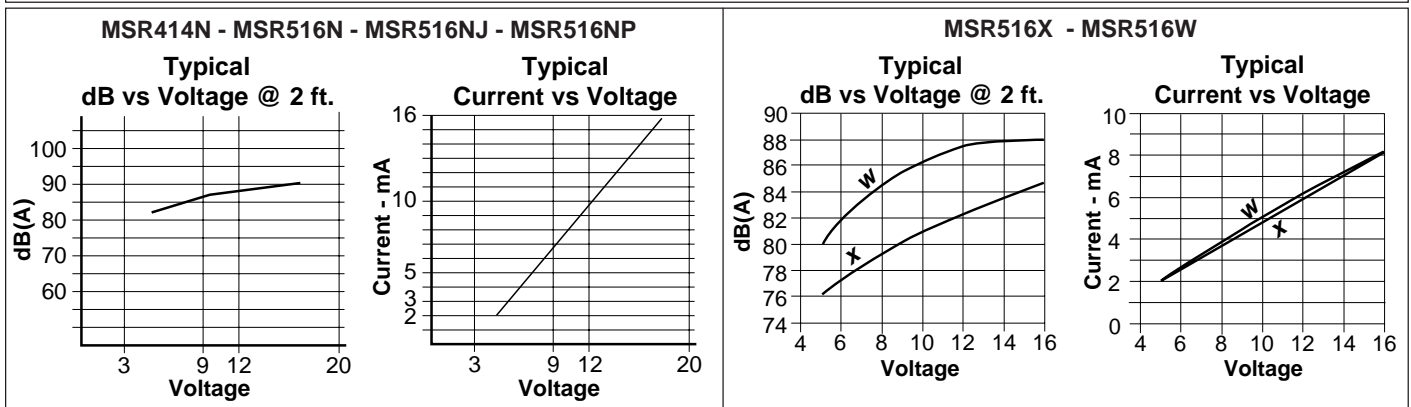

Because the operation of the audible signal device is dependent upon the circuit in which it is used, it is advisable to thoroughly test the selected device in the specific circuit and application to assure mechanical and electrical compatibility and verify system performance.

Models MSR320 & MSO320 Sonalert® Audible Signal Devices



- Made in USA
- Low Power Consumption
- Low Cost
- Compact Profile
- Piezo Tone Quality
- Wave Solderable

GENERAL SPECIFICATION

Resonant Frequency:
3.40 ±.4 kHz

Min. Sound Pressure @ 12VDC
75 db(A) @ 2ft.

Rated Voltage:
3-20 VDC to +65°C

Max. Current:
3-16 mA @ 3-20 VDC

Operating Temperature:
-20°C to +65°C

Storage Temperature:
-30°C to +80°C

Solder Temperature:
+270°C for 3 seconds

Case Material
VALOX (UL94V-0)

Weight (Typical):
3.5 grams

APPLICATIONS

Fire Alarm
Crime Prevention Alarm
Call Buzzer
Automotive
Clocks
Cash Registers
P.O.S. Equipment
Medical Instruments
Electrical Instruments

Shape and Dimensions (mm)

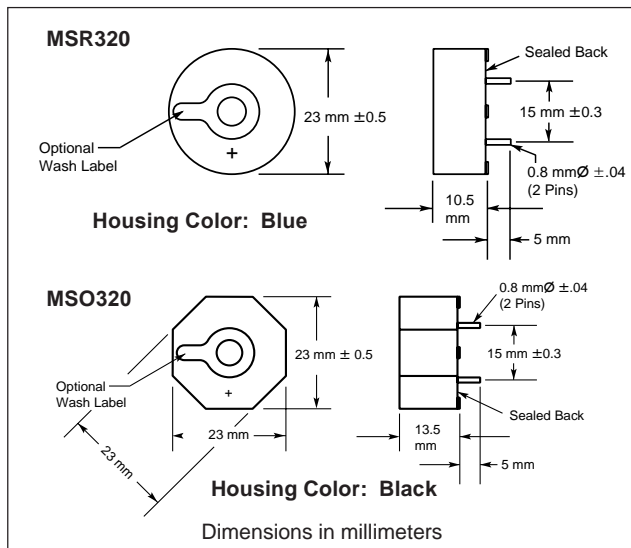

Characteristics

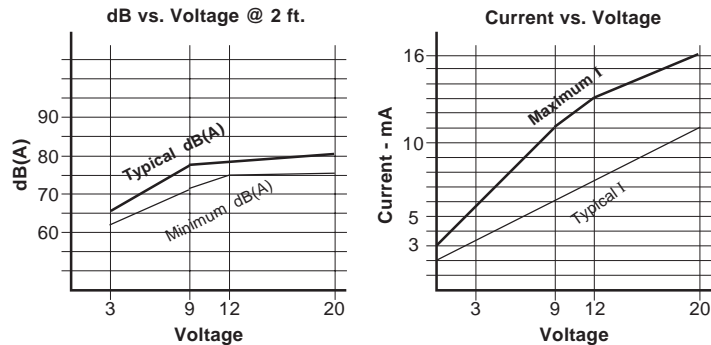

Parts similar to MSR320 & MSO320 have passed ESD (ElectroStatic Discharge) testing to levels 1, 2 & 3 per MIL-STD-883D.

The MSR320 and MSO320 are piezoelectric audible signal devices with a built-in oscillator circuit. They are suitable replacements for the MCP320B2 and MCP320.

The MSR320 and MSO320 are suitable for wave soldering when ordered with the sound emission hole covered with a wash label. The recommended maximum temperature and exposure time for wave soldering is +270° C and 3 seconds respectively.

Optional wash label may be ordered by adding 'S' to model number.

Example: MSR320S
MSO320S

Typical Reference Conditions for Various Applications

Sound Pressure @ 12VDC

90 db(A) @ 10 cm
81 db(A) @ 30 cm
75 db(A) @ 2 ft. (Spec)
72 db(A) @ 100 cm

Based on U.S. Government data and comments from the field, the total available market (TAM) for audible signals is vast and growing at a significant rate. Understanding the potential of this market, Mallory Sonalert Products, Inc. is dedicated to manufacturing the highest quality audible signals, assuring customers they will experience high reliability with all Sonalert® products. Our mission in designing audible devices is to meet or exceed customer and industry standards.

Because the operation of the audible signal device is dependent upon the circuit in which it is used, it is advisable to thoroughly test the selected device in the specific circuit and application to assure mechanical and electrical compatibility and verify system performance.

Environmental Specifications

Sonalert® Audible Signal Devices



Surge Voltage

15% over maximum rated voltage applied for less than one minute.

Reverse Voltage – DC Models

Maximum reverse polarity equal to rated voltage for one minute. Some models may sound softly when subjected to reversed polarity voltage.

Life Specification

Continuous – 250 hours continuous operation at 65°C with maximum rated voltage applied.

Intermittent – A duty cycle of 1 minute on, 5 minutes off, a minimum of 10,000 times at room temperature and maximum rated voltage applied.

Life Expectancy

7 years under normal operating conditions

Storage Temperature

-40°C to +85°C

Operating Temperature

-30°C to +65°C

Humidity

The Sonalert® signal should operate after having been subjected to 95% relative humidity at +40°C continuously for 100 hours. After removal from test, the unit should be allowed to dry a minimum of 4 hours at room temperature before operation. Units should deliver original output characteristics.

Vibration

The Sonalert® signal should be mounted in the standard manner on a mounting panel. The specimens should be subjected to a harmonic motion having an amplitude of 0.03 inch (0.06 inch maximum total excursion). The frequency should be varied uniformly between a limit of 10 and 55 Hertz. The entire frequency range from 10 to 55 Hertz and return to 10 Hertz should be traversed in approximately one minute. Motion should be applied for two hours in each of 3 mutually perpendicular planes (total 6 hours). This test should be conducted while the Sonalert® signal is not operating. After completion of test, Sonalert® signals should meet specifications.

Salt Spray

The Sonalert® signal should meet specified operating conditions after completing 96 hours in an atomized salt spray while not operating. The spray should consist of a 5% salt solution atomized by a forced air supply. The solution should be sprayed through a nozzle into a chamber maintained at 35°C. After salt spray, the unit should be removed and washed in running water not warmer than 40°C. A soft hairbrush or plastic bristle brush should be used, lightly brushing to remove salt deposits from the unit. The cleaned Sonalert® signals should be placed on absorbent material with the nose pointed downward and allowed to dry at room temperature for 24 hours prior to use.

"EXCEPT SBM & SNP MODELS"

Terminal Strength

5 pounds, applied axially for a period of 5 minutes. This is considered a destructive test.

Loudness

The loudness of sound heard from a Sonalert signal depends upon, among other things, the hearing sensitivity of the listener, the frequency of the sound, the distance to the listener, the density and humidity of the air, the design of the Sonalert signal and the voltage applied. Technically, loudness as perceived by the human ear, is measured in sones and this unit may be used to judge the relative loudness between sounds. For example, a sound with a loudness of 4 sones will sound about 4 times louder than a sound of 1 sone. Because loudness at the listener's location is dependent upon the environment, it is not specified for Sonalert signals.

Sound Pressure

Sonalert signals generate air pressure waves which travel through the air to the listener's ear where they produce a sensation of sound. The amount of pressure produced depends upon the loudness and the frequency ratings of the Sonalert signal. Sonalert signal frequencies have been selected for maximum loudness with minimum amount of sound pressure.

Measurements of sound air pressure are expressed as a ratio compared to a pressure of .0002 dynes per square centimeter. This is the smallest sound pressure heard by the average person. The largest pressure that can be heard before pain is felt is about 3 million times higher. For measurement convenience, this wide pressure range is converted to a logarithmic ratio and expressed in decibels (dB) according to the formula:

$$dB = 20 \text{ Log } \frac{\text{measured pressure}}{.0002 \text{ dynes/cm}^2}$$

The threshold of hearing has a ratio of 1:1, or a dB of 0. The threshold of pain has a ratio of 3 million:1, or a dB of 130.

Sound Pressure Change with Distance

When the sound pressure leaves the Sonalert signal, it radiates in all directions and is about 2 or 3 dB greater in the direction the open grill is facing. As the sound pressure travels towards the listener, it covers a greater area with a corresponding reduction in pressure at any one point until it is below the threshold of hearing.

For distances shorter than 50 meters, sound pressure drops 6 dB each time the distance traveled is doubled. Variations as much as ±8 dB may occur inside a room or around large objects such as buildings due to echo cancellation and reinforcement effects.

For distances longer than 2KM, air friction reduces sound air pressure about 10 dB/KM @ 1500 Hz, and 20 dB/KM @ 3000 Hz. Of course, the reduction in sound pressure between stationary points also depends upon wind direction and turbulence.

Perhaps the loudest known sound was caused by the eruption of Mt. Krakatua in 1883 which was estimated at 170 dB at 3 miles.

Sound Pressure Specifications

Since sound pressure decreases as it travels from the Sonalert signal, standard measurements must be made at a standard distance. Standard measurements are made at a distance of 2 feet in an anechoic chamber; or 10 feet above the ground in an open area with no wind. Sound pressure specifications for all Sonalert signal models are shown in the Catalog Number lists.

Frequency

Each Sonalert signal model has its own frequency (tone) which cannot be changed. Models are available to provide frequencies from 1900 to 4500 Hz. For equal sound pressure, 1900 Hz Sonalert signals sound softer and more pleasant than 2900 Hz and 4500 Hz Sonalert signals.

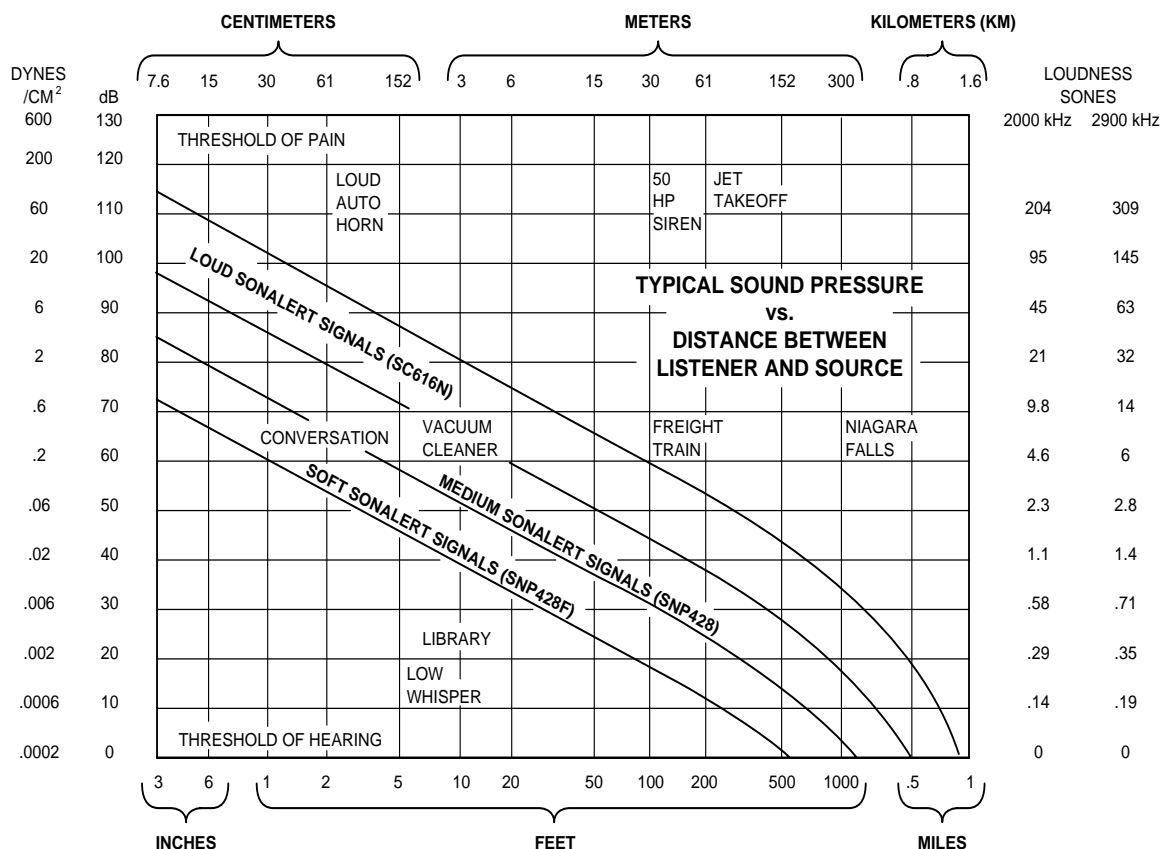

Typical Performance Curves Sonalert® Audible Signal Devices

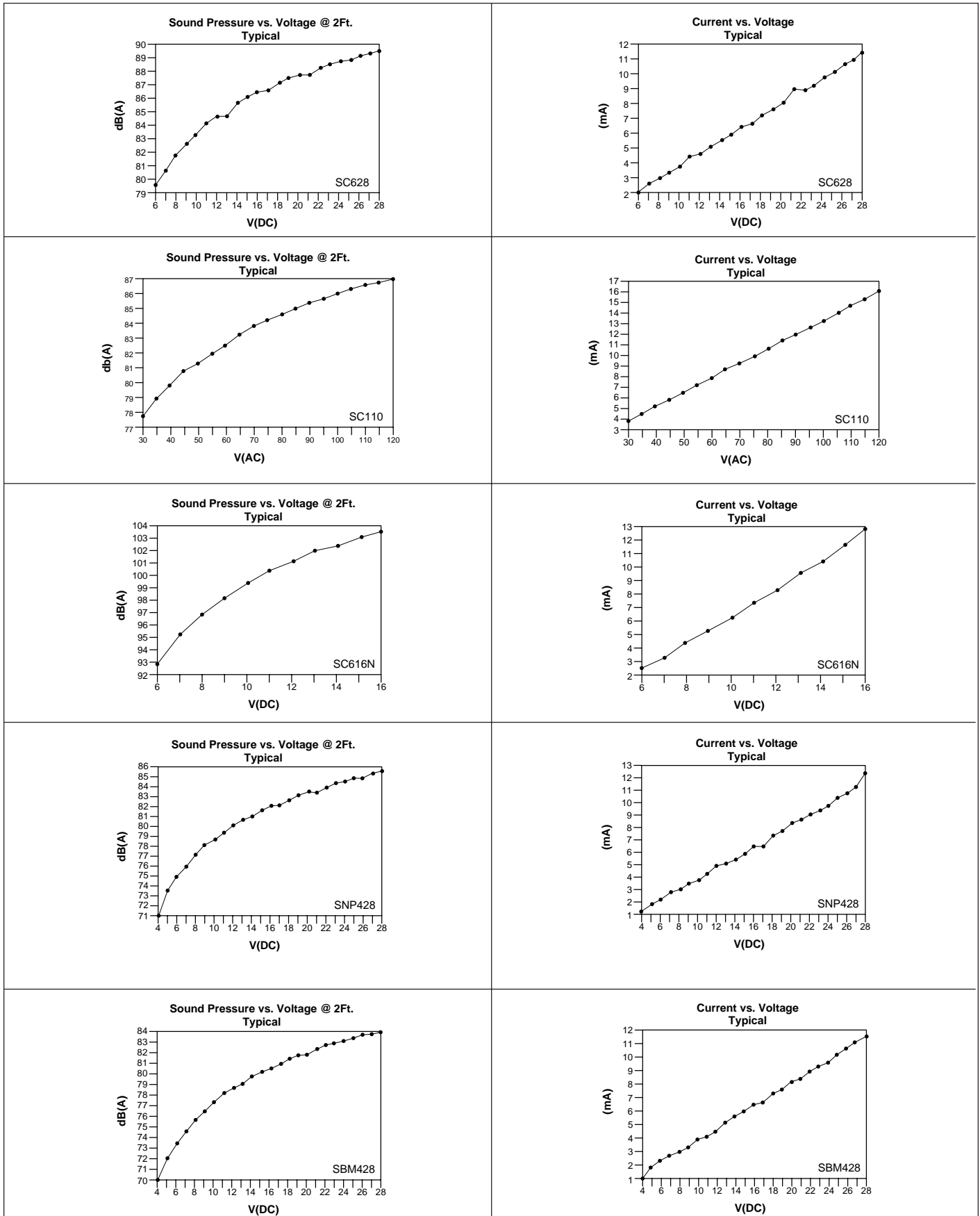

Military Sonalert® Audible Signal Devices



Quality Specifications

Operating

100% measurement of sound output and frequency at +25° C. Data is supplied with parts. Operation of each part confirmed at -40° C and +85° C.

Environmental

MIL Std. 105D Level II single normal inspection .65 AQL

Life Specifications

500 hours continuous operation at 85° C and maximum rated voltage applied.
10,000 cycles one minute on, 5 minutes off at 25° C and maximum rated voltage applied.

Life Expectancy

10 years under normal operating conditions

Operating Temperature

-40° C to +85° C

Storage Temperature

-65° C to +85° C

Altitude Change

10,000 feet per minute maximum

For applications requiring operation over extended temperature ranges, or in extreme environmental conditions, military models are recommended. Exposed surface of the sound transducer is treated with a corrosion protective coating. Mounting nut is anodized aluminum. Terminals are tin plated brass with nickel plated 6-32 screws. All units are marked with Mallory logo, part number, polarity and date code per MIL-STD-1285. Marking is permanently preserved by a layer of clear epoxy. Customer part number may be included on label if desired. A certificate of compliance to Mallory Sonalert Products, Inc. specifications will be supplied if requested.

Black plastic case and black anodized aluminum mounting nut is standard. To specify olive drab case and mounting nut, add G to part number. *Example:* SC628MG. To specify black case and clear anodized mounting nut, add C to part number. *Example:* SC628MC.

Mallory Sonalert Products, Inc.
Cage Code – 90201

Environmental Specifications

Test	MIL-STD-202 Method	Test Condition
Thermal shock	107	A
Humidity	103	B
Salt spray	101	A
Shock	213	H
Vibration	201	None
Terminal strength	211	A (5 lbs.)

Because the operation of the Sonalert audible signal device is dependent upon the circuit in which it is used, it is advisable to thoroughly test the selected device in the specific circuit and application to assure mechanical and electrical compatibility and verify system performance.

Catalog Number	Loudness Category	Mounting Method	Case Style	Frequency ± 500 Hz	Minimum Sound Pressure dB (A) at Two Feet		Operating Voltage * AC/DC Non-Polar All Others DC Only		Typical Operating Current (mA)	
					At Min. V	At Max. V	■ Min.	Max.	At Min. V	At Max. V
Continuous Tones										
SC616MN	Loud	Panel	C-8	2900	80	95	6	16	6	22
SC628MN	Loud	Panel	C	2900	80	90	6	28	4	16
SC648MAN	Loud	Panel	D	2900	80	95	10	48	4	26
SC628M	Medium	Panel	C	2900	68	80	6	28	4	14
SC628MD	Medium	Panel	C	1900 ±300	60	75	6	28	5	20
SC628MH	Medium	Panel	C	4500	68	80	6	28	4	14
SC648M	Medium	Panel	C	2900	68	80	10	48	5	20
SC648MD	Medium	Panel	C	1900 ±300	60	75	10	48	5	20
SC628MA	Medium	Panel	D	2900	68	80	* 6	* 28	4	22
SC628MAH	Medium	Panel	D	4500	68	80	* 6	* 28	4	16
SC648MA	Medium	Panel	D	2900	68	80	* 10	* 48	4	19
SC648MAH	Medium	Panel	D	4500	68	80	* 10	* 48	4	19
SC110M	Medium	Panel	D	2900	68	80	* 30	* 120	4	18
SC110MH	Medium	Panel	D	4500	68	80	* 30	* 120	5	18
SC250M	Medium	Panel	D	2900	68	80	* 60	* 250	4	10
Fast Pulse										
Turns on and off at 2 to 9 pulses per second depending upon voltage at 50% duty cycle.										
SC628MNP	Loud	Panel	D	2900	80	90	6	28	4	16
SC628MP	Medium	Panel	D	2900	68	80	6	28	4	16
SC628MHP	Medium	Panel	D	4500	68	80	6	28	4	164
Fast Warble										
Produces two tones alternately when used with additional continuous unit.										
SC628MW	Medium	Panel	D-1	2900	68	80	6	28	4	16
Continuous or Fast Pulse										
Dual mode operation.										
SC616MPU	Medium	Panel	C-7	2900	68	78	6	16	3	12

* For AC Operation
(AC Voltage is RMS for 50 or 60 Hz Power Line)

■ Minimum voltage specified for sound test does not represent sound turn-on or turn-off points. Units will sound at lower voltages.

Case Style A

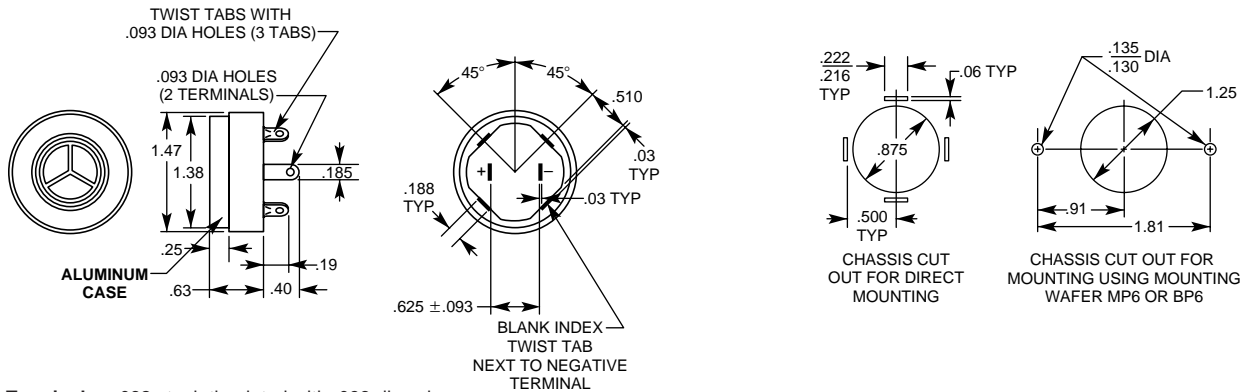

Terminals - .032 steel, tin plated with .093 dia. wire hole, will accept standard 3/16" quick disconnect.

Dimensions in inches

Mounting - Four Twist Tabs per EIA std. RS395 are provided for mounting.

Terminals are electrically isolated from case and Twist Tabs.

Case Style A may also be mounted using wafers.

MP6 (Metal) - For uninsulated mounting

BP6 (Bakelite) - To insulate case from chassis.

Example

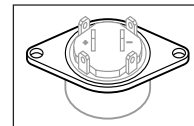

Case Style B

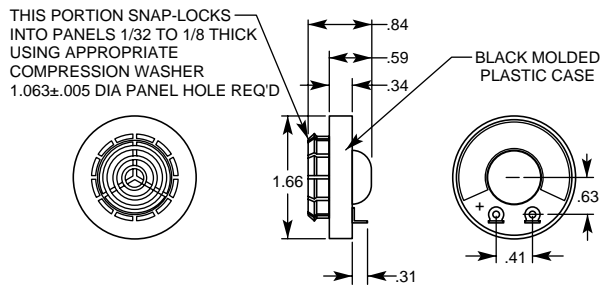

Terminals - .022 brass, hot tin finish with .065 wire hole. Terminal will accept standard 1/8" quick disconnect.

Case Style B - 1

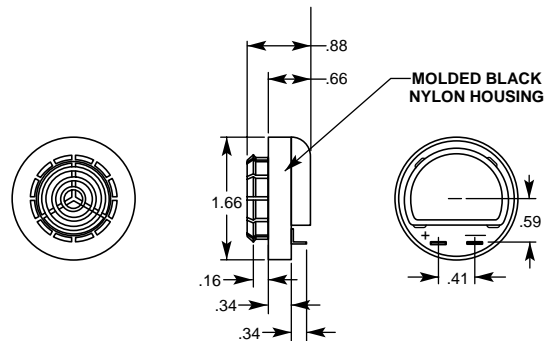

Typical Panel Installation Case Style B

Mounting - Panel hole 1.063 ± .005 diameter should be punched from the back side so that locking fingers enter on the slightly rounded edge of the hole. Assemble proper **compression washer** and press into panel hole until locking fingers snap over hole edge. Installation pressure should be applied only at the circumference of the device.

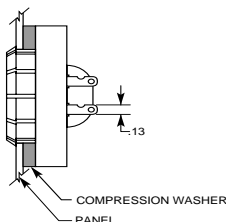

Compression Washer

Catalog Number	Thickness	Panel Thickness
PW1	.063	11-12GA (.125-.109)
PW2	.125	13-17GA (.093-.056)
PW3	.187	18-22GA (.050-.031)

Material: Black ester foam Compression 5:1
 Size : 1.06" I.D. x 1.50" O.D. (Ref.)

Dimensions in inches

Case Style C

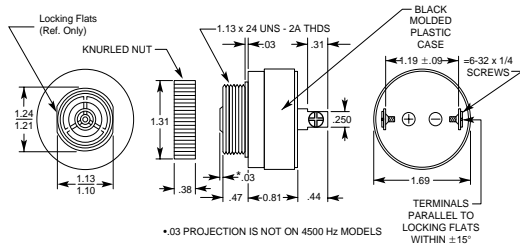

*.03 PROJECTION IS NOT ON 4500 Hz MODELS

Case Style C-1

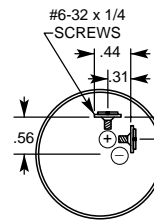

C-2

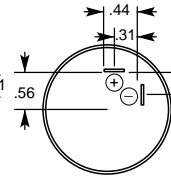

C-3

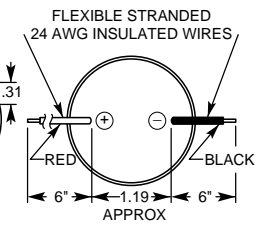

C-8: Same as Style C except terminal spacing is 1.31".

C-11: Same as Style C-2 except terminal height is .56".

Case Style D

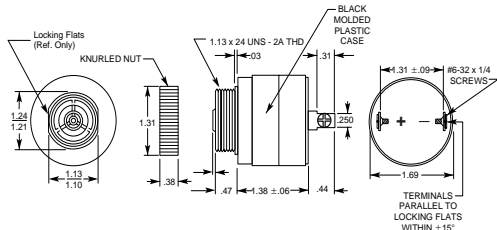

3 Way Terminals - .032 brass, tin plated, tapped for #6-32 screw. Two #6-32 nickel plated brass screws included. (Terminal screw maximum torque = 5 in.-lbs.) Will accept 1/4" quick disconnect with 3/16" opening. Terminals are also solderable

Case Style D-1 and C-7

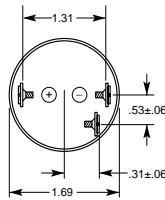

Mounting - Remove black plastic nut and insert threaded front through 1.25" hole punched in panel. If orientation is needed, note locking flats on drawing. Screw nut back on. Do not overtighten.

Case Style D-4

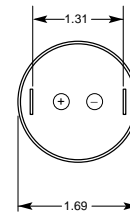

Optional Mounting Nuts - To substitute natural finished aluminum or anodized black aluminum nut for the standard plastic nut, purchase catalog numbers 'CNR1' or 'BNR1' respectively as shown on page 14.

Case Style E

Outline dimensions are the same as case style D except length is changed to 1.94" ± .094" (1-15/16 ± 3/32).

Case Style F

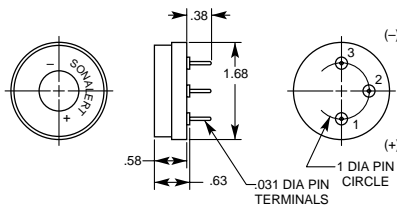

Terminals - .031 dia. soldercoated copperclad steel

Mounting - Insert into printed circuit board and hand or machine solder.

Electrical Connections - SBM2, SBM428, SBM616P, SBM616J - When pin 1 is connected to + voltage and pin 3 is connected to common (-), unit will sound. Pin 2 is for mechanical support only and is not connected internally.

SBM616PU, SBM616JU - When pin 1 is connected to + voltage, and pin 3 is connected to common (-), and the voltage on pin 2 is within 1.25V of pin 1 or higher, the unit will sound a pulsing tone. When the voltage on pin 2 is within .9V of pin 3 or lower, the unit will sound a continuous tone. The maximum voltage which may be applied to pin 2 before damage may occur is ± 16V referenced to pin 3. Pin 2 input impedance is 110K ohm.

Case Style G

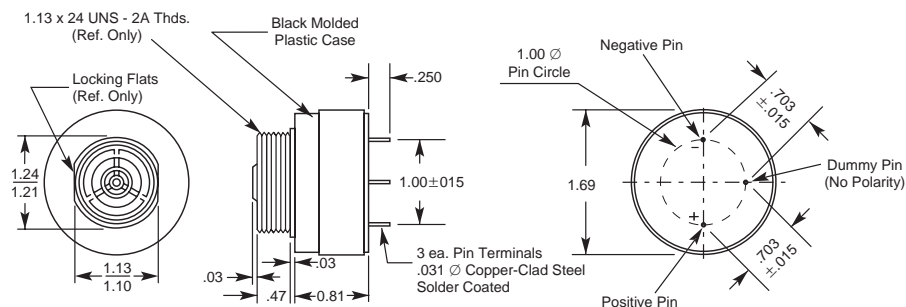

Mounting - Insert Pin Terminals into Circuit Board and Solder

All Dimensions in inches

Accessories

Sonalert® Audible Signal Devices



Manual Volume Control

Consisting of 3 component parts

Baffle Plate

Shutter

Screw

Sonalert Sold Separately

Produces approximately -10dB to -15dB attenuation

Catalog Number SCVC

Electrical Mounting Box

Used to mount Sonalert® signal case styles C and D on standard 3/4" electrical conduit. 3 - 1/2" diameter, 2" deep ABS plastic.

Catalog Number SCMB

Sonalert® Mounting Nuts

1.13 x 24 UNS - 2A THD
Halfway Through

1.31

.38

Material	Catalog Number
Anodized Black Aluminum (Standard on Military units)	BNR1
Anodized Clear Aluminum	CNR1
Black Plastic (Nylon 6/6) (Standard on Industrial and Commercial units)	PNR1

SG1 Sonalert® Gasket

1.63 ± .03

1.24 ± .03

Material = Neoprene

.062 ± .005

Assembly Procedure:
Remove knurled nut and assemble SG1 Gasket onto threaded neck of classic Sonalert®. Place threaded neck through panel hole and secure with nose ring (K-nut). Hand tighten only.

RSB1 Vinyl Boot

3/8" Dia Hole

1 5/8"

1 1/2"

Material = Black Vinyl

Recommended especially for 110Vac & 250 Vac models, or any other classic ('SC') models where terminal insulation is desired.

All Dimensions in inches

Mounted Piezo Transducers



Features

- Low current consumption and high sound output
- Extremely clear and penetrating sound
- Small size and light weight
- No electronic generated EMI or RFI

Applications

- Office equipment
- Communication equipment
- Home appliances
- Alarms
- Computers
- Vehicles

Part Numbering

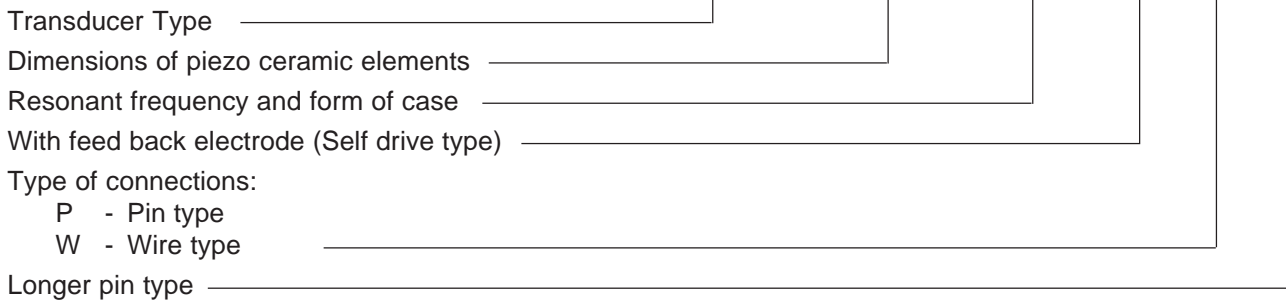

Transducers have no internal drive circuitry and must be driven by typical circuits as shown below.

Typical Drive Circuits

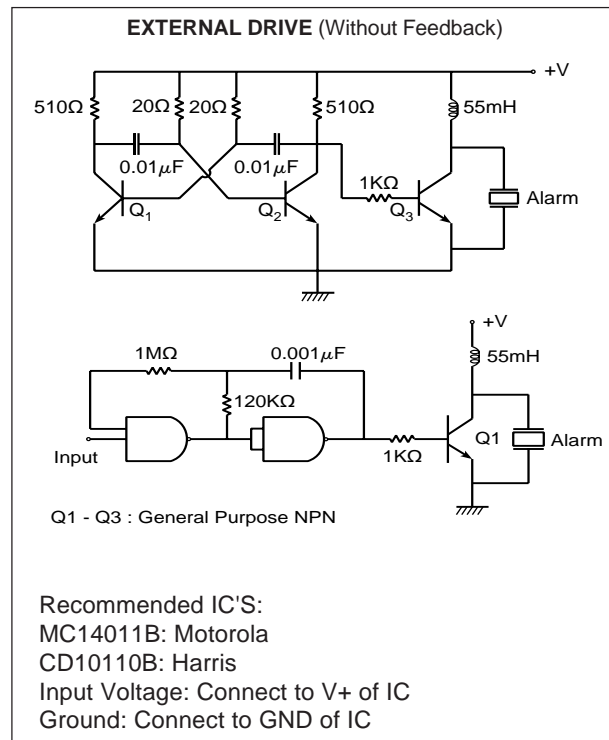
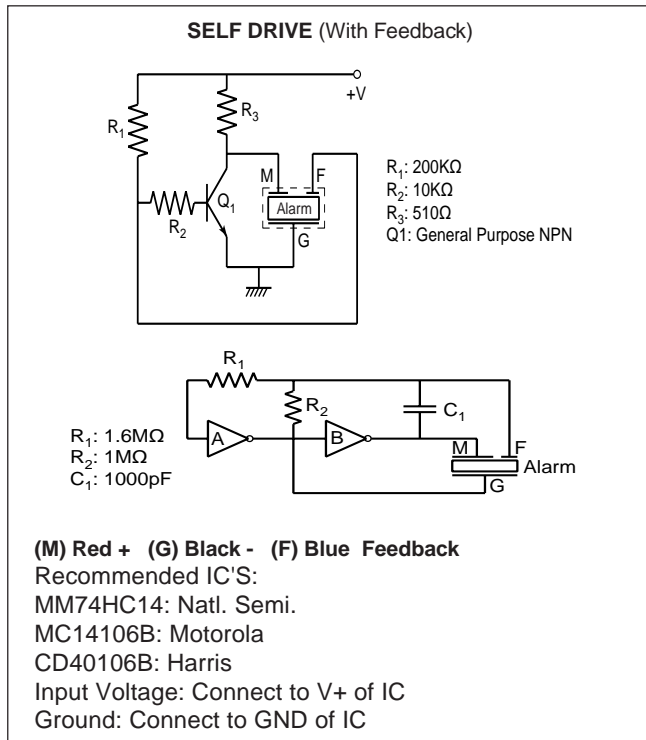

Piezo - External Drive (No Feedback)

Bold-face items are surface mount devices

Catalog Number	Type	Resonant Frequency (kHz ± 0.5)	dB (Min) @ Res. Freq. 10cm, 5v square wave	Operating Voltage (Vp-p)	D x H (mm)	Figure	Mounting & Features	Pitch
PT-2746W	External Drive	4.5	90	30	30 x 5	1	2 wire	
PT-1250W	External Drive	4.8	80	30	13.8 x 4	1	2 wire	
PT-1550W	External Drive	5.0	80	25	16.5 x 4	1	2 wire	
PT-1550WL	External Drive	5.0	80	25	16.5 x 4	1	2 wire - Double Adhesive Back	
PT-2725W	External Drive	2.5	90	30	30 x12	2	Flange Mount (35 mm c/c) - 2 wire	
PT-3529W	External Drive	2.9	95	30	42 x16	2	Flange Mount (50 mm c/c) - 2 wire	
PT-2130W	External Drive	3.0	90	30	24 x 9.5	2	Flange Mount (29 mm c/c) - 2 wire	
PT-2736W	External Drive	3.5	90	30	30 x10	2	Flange Mount (39 mm c/c) - 2 wire	
PT-2038W	External Drive	3.8	90	30	24 x 5	2	Flange Mount(29 mm c/c) - 2 wire	
PT-1540W	External Drive	4.0	80	25	17 x 8.5	2	Flange Mount (23 mm c/c) - 2 wire	
PT-2040W	External Drive	4.0	90	30	22 x 9.2	2	Flange Mount (28.5 mm c/c) - 2 wire	
PT-2745W	External Drive	4.5	90	30	30 x 5	2	Flange Mount (35 mm c/c) - 2 wire	
PT-2060W	External Drive	6.0	90	30	24 x 5	2	Flange Mount (29 mm c/c) - 2 wire	
PT-2020P	External Drive	2.0	80	30	22 x 7.2 x 26.6	5	P.C. Board - Edge Mount - 2 blade	(12.5 mm c/c)
PT-2725P	External Drive	2.5	90	30	30 x12	1	P.C. Board - 2 pin	(15 mm c/c)
PT-2726P	External Drive	2.5	90	30	30 x10	1	P.C. Board - 2 pin	(15 mm c/c)
PT-2726W	External Drive	2.5	80	30	30 x 8.7	3	P.C. Board - Snap Mount - 2 wire	
PT-2130P	External Drive	3.0	90	30	24 x 9.5	1	P.C. Board - 2 pin	(15 mm c/c)
MAT4530P	External Drive	3.0	100	30	See Figure	4A	P.C. Board - 2 blade	See Figure
PT-2736P	External Drive	3.5	90	30	30 x10	1	P.C. Board - 2 pin	(18 mm c/c)
PT-1540P	External Drive	4.0	80	25	17 x 9	1	P.C. Board - 2 pin	(10 mm c/c)
PT-1245P	External Drive	4.0	80	30	12.6 x 7.2	1	P.C. Board - 2 pin	(7.5 mm c/c)
PT-1240PE	External Drive	4.0	80	30	13.5 x 6.7	1A	P.C. Board - 2 pin - Sealed	(7.5 mm c/c)
PT-2040P	External Drive	4.0	90	30	22 x 9	1	P.C. Board - 2 pin	(10 mm c/c)
PT-1240P	External Drive	4.1	80	20	13.8 x 8.3	1	P.C. Board - 2 pin	(7.6mm c/c)
PT-2060P	External Drive	6.0	80	30	24 x 5.5	1	P.C. Board - 2 pin	(10 mm c/c)
★ AST100	External Drive	4.0	80	15	See Figure	14	Surface Mount	

* Surface Mount units are available taped & reeled by special order - Add TR to part number (AST100TR)

Piezo - Self Drive (With Feedback)

Catalog Number	Type	Resonant Frequency (kHz ± 0.5)	dB (Min) @ Res. Freq. 30cm, @ 12Vdc	Operating Voltage (Vp-p)	D x H (mm)	Figure	Mounting & Features	Pitch
PT-2725FP	Self Drive	2.5	85	3 - 28	30 x 10	4	3 blade - 3 mm standoff	See Figure
PT-2725FPL	Self Drive	2.5	85	3 - 28	30 x 10	4	3 blade - 6 mm standoff	
PT-2728FP	Self Drive	2.8	85	3 - 28	30.5 x 8 x 33	5	Edge Mount - 3 blade	
PT-2035FP	Self Drive	3.0	86	3 - 28	23.4 x 11	4	3 blade - 3 mm standoff	
PT-2035FPL	Self Drive	3.0	86	3 - 28	23.4 x 11	4	3 blade - 6 mm standoff	
PT-2036FP	Self Drive	3.0	86	3 - 28	24 x 11	4	3 blade - 6 mm standoff	
PT-2036FPL	Self Drive	3.0	86	3 - 28	24 x 11	4	3 blade - 12 mm standoff	
PT-3532FP	Self Drive	3.4	90	6 - 12	40 x 14	4	3 blade - 5.5 mm standoff	
PT-2735FP	Self Drive	3.5	88	3 - 28	30 x 10	4	3 blade - 3 mm standoff	
PT-2735FPL	Self Drive	3.5	88	3 - 28	30 x 10	4	3 blade - 6 mm standoff	
PT-2726FP	Self Drive	2.6	90	3 - 28	30 x 10	1	3 pin	p2(11 mm) ,P3(7 mm)
PT-3529FP	Self Drive	2.9	90	3 - 28	42 x 16	1	3 pin	p2 (10.5 mm), P3(8 mm)
PT-2130FP	Self Drive	3.0	80	1.5 - 30	24 x 9.5	1	3 pin	p2 (8.5 mm), P3 (4 mm)
PT-2732FP	Self Drive	3.2	90	3 - 28	30 x 8.5	12	3 pin - with standoffs	See Figure
PT-3534FP	Self Drive	3.4	105	3 - 28	39 x 20	1	3 pin - 4 mm standoff	p2 (10.5 mm), P3 (8 mm)
PT-2736FP	Self Drive	3.5	90	3 - 28	30 x10	1	3 pin	p2 (11 mm), P3 (7 mm)
PT-2742FP	Self Drive	4.2	90	3 - 28	30 x10	1	3 pin	p2 (11 mm), P3 (7 mm)
PT-2746FW	Self Drive	4.0	85	3 - 28	30 x 5	1	3 wire	
PT-2726FW	Self Drive	2.6	90	3 - 28	30 x10	2	Flange Mount (39 c/c) - 3 wire	
PT-3529FW	Self Drive	2.9	90	3 - 28	42 x 16	2	Flange Mount (50 c/c) - 3 wire	
PT-2130FW	Self Drive	3.0	80	1.5 - 30	24 x 9.5	2	Flange Mount (29 c/c) - 3 wire	
PT-2736FW	Self Drive	3.5	90	3 - 28	30 x10	2	Flange Mount (39 c/c) - 3 wire	
PT-2038FW	Self Drive	3.8	85	3 - 28	24 x 4.5	2	Flange Mount (29 c/c) - 3 wire	
PT-2745FW	Self Drive	4.0	85	3 - 28	30 x 5	2	Flange Mount (35 c/c) - 3 wire	
PT-2742FW	Self Drive	4.2	90	3 - 28	30 x10	2	Flange Mount (39 c/c) - 3 wire	
PT-2060FW	Self Drive	5.0	85	3 - 28	24 x 5	2	Flange Mount (29 c/c) - 3 wire	
PT-2065FW	Self Drive	6.0	85	3 - 28	24 x 4.5	2	Flange Mount (29 c/c) - 3 wire	

Mounted Transducers & Speakers



Piezo - Telephone Ringers

Catalog Number	Type	Resonant Frequency (KHz ± 0.5)	dB (Min) @ Res. Freq. 10cm 5V Square Wave	Operating Voltage (Max Vp-p)	D x H (mm)	Figure	Mounting & Features	Pitch
PT-4176P	Telephone Ringers	0.75	75	30	See Figure	11	2 pin	(25.4 mm c/c) (25.4 mm c/c)
PT-4175P	Telephone Ringers	0.75	87	30	44 x 14	1	2 pin	
PT-3110P	Telephone Ringers	1.1	85	30	34.5 x 10.3	1	2 pin	
PT-2030P	Telephone Ringers	2.0	80	25	See Figure	6	2 pin	
PT-4175W	Telephone Ringers	0.75	87	30	See Figure	10	Flange Mount (52 mm c/c) - 2 wire	Flange Mount (40 mm c/c) - 2 wire
PT-3110W	Telephone Ringers	1.1	85	30	34.5 x 9	2	Flange Mount (40 mm c/c) - 2 wire	

Electro-Magnetic Transducers

Bold-face items are surface mount devices

Catalog Number	Type	Resonant Frequency (± 500 Hz)	dB (Min) @ Res. Freq. 10cm,	Operating Voltage	D x H (mm)	Figure	Mounting & Features	Pitch
PB-1221P	Electro-Magnetic Transducer	2048	80 @ 1.5V	1.25 ~ 2.5	12 x 8.5	1	2 pin	(6.5 mm c/c)
PB-1221PE	Electro-Magnetic Transducer	2048	80 @ 1.5V	1.25 ~ 2.5	12 x 10	1A	2 pin - Sealed	(6.5mm c/c)
PB-1620P	Electro-Magnetic Transducer	2048	80 @ 1.5V	1.25 ~ 2.5	See Figure	9	2 pin - Sealed	(7.6mm c/c)
PB-1220P	Electro-Magnetic Transducer	2048	85 @ 1.5V	1.25 ~ 2.5	12 x 8.5	1	2 pin	(6.5 mm c/c)
PB-1220PE	Electro-Magnetic Transducer	2048	85 @ 1.5V	1.25 ~ 2.5	12 x 10	1A	2 pin - Sealed	(6.5 mm c/c)
PB-1621P	Electro-Magnetic Transducer	2048	85 @ 5V	4 ~ 7	See Figure	9	2 pin - Sealed	(7.6mm c/c)
PB-1622P	Electro-Magnetic Transducer	2048	85 @ 12V	10 ~ 14	See Figure	9	2 pin - Sealed	(7.6mm c/c)
PB-1224PE	Electro-Magnetic Transducer	2400	85 @ 1.5V	1.25 ~ 2.5	12 x 10	1A	2 pin - Sealed	(6.5mm c/c)
PB-1224PE-05	Electro-Magnetic Transducer	2400	85 @ 5V	4.5 ~ 5.5	12 x 10	1A	2 pin - Sealed	(6.5mm c/c)
PB-1224PE-12	Electro-Magnetic Transducer	2400	85 @ 12V	9 ~ 15	12 x 10	1A	2 pin - Sealed	(6.5mm c/c)
PB-0927P	Electro-Magnetic Transducer	2731	85 @ 5V	4.5 ~ 5.5	9 x 5.4	1	2 pin	(4 mm c/c)
PB-1221W	Electro-Magnetic Transducer	2048	80 @ 1.5V	1.25 ~ 2.5	12 x 8.5	1	2 wire	** (10 mm height)
PB-1220W	Electro-Magnetic Transducer	2048	85 @ 1.5V	1.25 ~ 2.5	12 x 8.5	1	2 wire	
★ AST500	Electro-Magnetic Transducer	2400	85 @ 1.5V	1.2 ~ 3	See Figure**	16	Surface Mount	
★ AST501	Electro-Magnetic Transducer	2400	85 @ 1.5V	1 ~ 2	See Figure	16	Surface Mount	
★ AST600	Electro-Magnetic Transducer	2400	87 @ 5V	4 ~ 8	See Figure**	16	Surface Mount	
★ AST605	Electro-Magnetic Transducer	2400	87 @ 5V	4 ~ 7	See Figure	16	Surface Mount	
★ AST612	Electro-Magnetic Transducer	2400	87 @ 12V	8 ~ 16	See Figure	16	Surface Mount	
★ AST200	Electro-Magnetic Transducer	2731	85 @ 3V	2 ~ 5	See Figure	15	Surface Mount	
★ AST700	Electro-Magnetic Transducer	3200	85 @ 1.5V	1.2 ~ 1.7	See Figure	17	Surface Mount	
★ AST800	Electro-Magnetic Transducer	3200	87 @ 3V	2 ~ 4.5	See Figure	17	Surface Mount	

* Surface Mount units are available taped & reeled by special order - Add TR to part number (AST500TR)

Miniature Speakers (Cone Type)

Catalog Number	Type	Resonant Frequency (Hz ± 200)	dB (Min) @ Res. Freq. @ 10cm (3Vp-p)	Maximum Input (Watt)	D x H (mm)	Figure	Mounting & Features	Pitch
PB-2712W	Miniature Speaker - Cone Type	1250	85	0.2	30 x 13.5	2	Flange Mount - 2 wire	
PB-2015W	Miniature Speaker - Cone Type	1500	75	0.15	23 x 8.8	2	Flange Mount - 2 wire	
PB-2712P	Miniature Speaker - Cone Type	1250	85	0.2	30 x 13.5	1	P.C Board - 2 pin	(15.0mm c/c)
PB-2015P	Miniature Speaker - Cone Type	1500	75	0.15	23 x 8.8	1	P.C Board - 2 pin	(10.0mm c/c)

All speakers have 8 Ohm impedance

Transducer & Indicator Figures

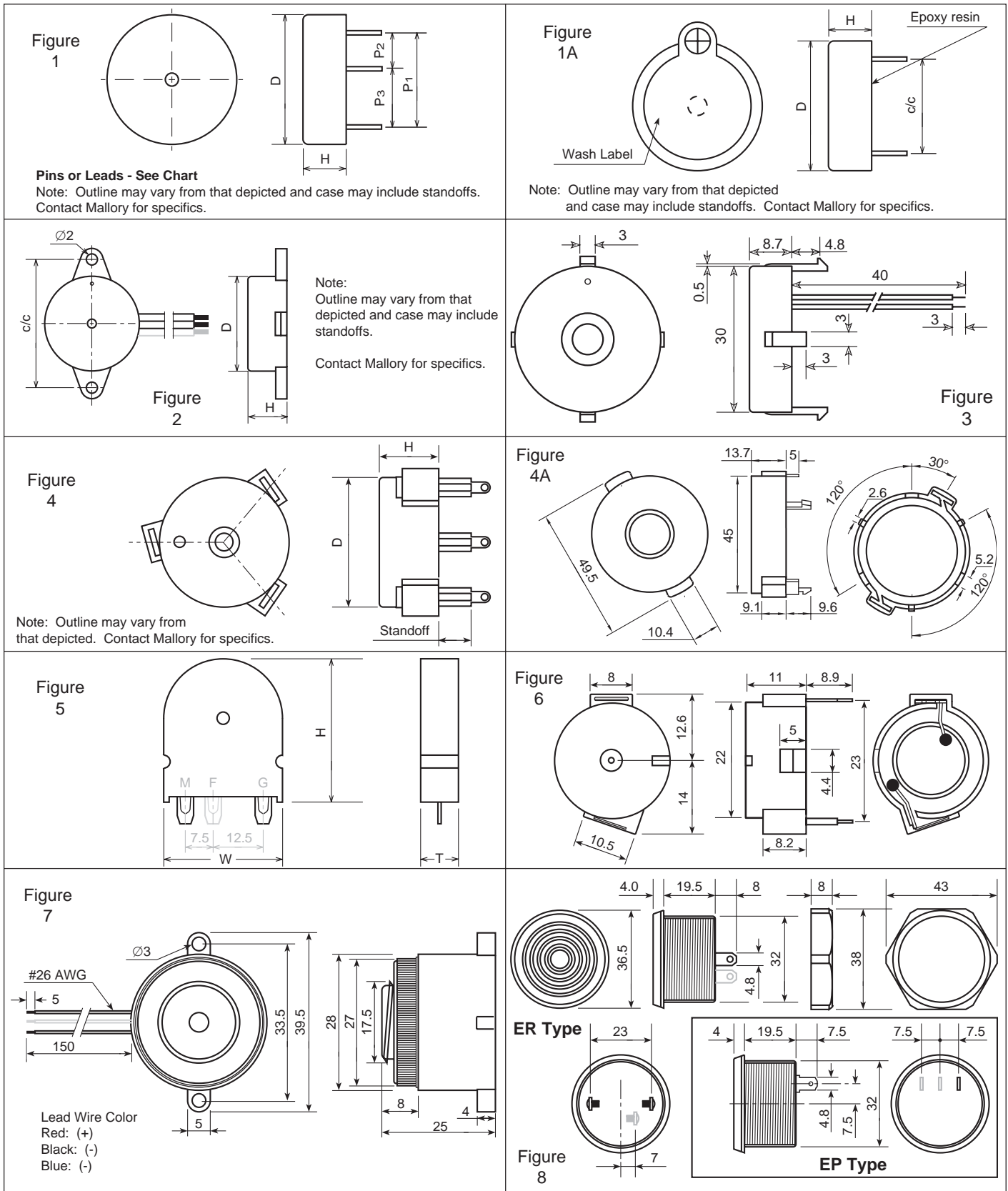

All dimensions are in millimeters

Features

- Low current consumption and high sound output
- Extremely clear and penetrating sound
- Small size and light weight
- No electronic generated EMI or RFI

Applications

- Office equipment
- Communication equipment
- Home appliances
- Alarms
- Computers
- Vehicles

Part Numbering

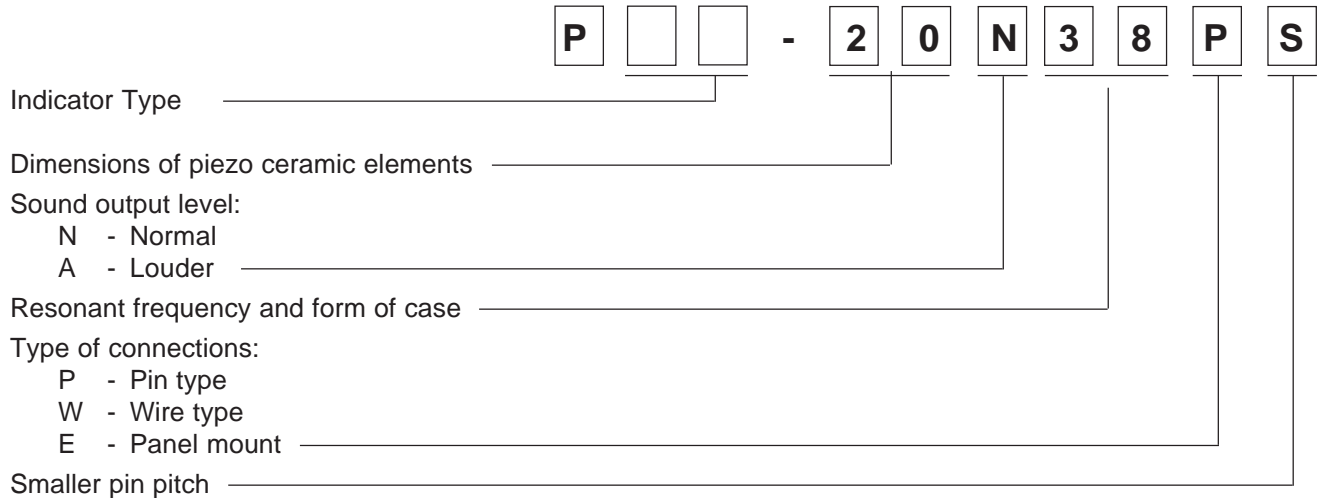

Indicators have internal drive circuitry and require only DC source voltage for operation.

Piezo Indicators

Catalog Number	Tone	Oscillating Frequency (kHz ± 0.5)	dB (Min) @ 12V @ 30cm	Operating Voltage (VDC)	D x H (mm)	Figure	Mounting & Features	Pitch
PK-27N25W	C	2.5	90	3 ~ 28	30 x 16	2	Flange Mount (39 c/c) - 2 wire	
PK-27N26W	C	2.5	90	3 ~ 28	30 x 10	2	Flange Mount (39 c/c) - 2 wire	
PK-20A25W	C	2.5	95	3 ~ 24	23 x 18	2	Flange Mount (29 c/c) - 2 wire	
PK-27A25W	C	2.5	95	3 ~ 24	30 x 16	2	Flange Mount (39 c/c) - 2 wire	
PK-35N29W	C	2.9	90	3 ~ 28	42 x 16	2	Flange Mount (50 c/c) - 2 wire	
PK-35A29W	C	2.9	95	3 ~ 24	42 x 16	2	Flange Mount (50 c/c) - 2 wire	
PK-21N30W	C	3.0	80	1.5 ~ 30	24 x 9.5	2	Flange Mount (29 c/c) - 2 wire	
PK-21A29W	C	3.0	85	3 ~ 24	24 x 13.5	2	Flange Mount (28.4 c/c) - 2 wire	
PK-27N35W	C	3.5	90	3 ~ 28	30 x 16	2	Flange Mount (39 c/c) - 2 wire	
PK-27N36W	C	3.5	90	3 ~ 28	30 x 10	2	Flange Mount (39 c/c) - 2 wire	
PK-27A35W	C	3.5	95	3 ~ 24	30 x 16	2	Flange Mount (39 c/c) - 2 wire	
PK-20N38W	C	3.8	85	3 ~ 28	23 x 18	2	Flange Mount (29 c/c) - 2 wire	
PK-20A38W	C	3.8	95	3 ~ 24	23 x 18	2	Flange Mount (29 c/c) - 2 wire	
PK-27N35EP	C	3.5	90	3 ~ 28	See Figure	8	Panel Mount - Tamper Proof	
PK-27N35ER	C	3.5	90	3 ~ 28	See Figure	8	Panel Mount - Tamper Proof	
PK-27A35EP	C	3.5	95	3 ~ 24	See Figure	8	Panel Mount - Tamper Proof	
PK-27A35ER	C	3.5	95	3 ~ 24	See Figure	8	Panel Mount - Tamper Proof	
PK-20A35EW	C	3.5	95	3 ~ 24	See Figure	7	Panel or Flange Mount - 2 wire	
PK-27N25PS	C	2.5	90	3 ~ 28	30 x 16	1	P.C. Board - 2 pin	(15 mm c/c)
PK-27N26PS	C	2.5	90	3 ~ 28	30 x 10	1	P.C. Board - 2 pin	(15 mm c/c)
PK-20A25P	C	2.5	95	3 ~ 24	23 x 18	1	P.C. Board - 2 pin	(15 mm c/c)
MCP320B2	C	2.5	95	3 ~ 20	23 x 18	1	P.C. Board - 2 pin	(15 mm c/c)
PK-27A25PS	C	2.5	95	3 ~ 24	30 x 16	1	P.C. Board - 2 pin	(15 mm c/c)
MAS800	C	2.8	103 @ 2 ft	9 ~ 12	See Figure	9A	P.C. Board - 2 pin - Sealed Back	(15 mm c/c)
MAS800S	C	2.8	103 @ 2 ft	9 ~ 12	See Figure	9A	P.C. Board - 2 pin - Sealed	(15 mm c/c)
MAS806	C	2.8	103 @ 14V @ 2ft	5 ~ 14	See Figure	9A	P.C. Board - 2 pin - Sealed Back	(15 mm c/c)
MAS806S	C	2.8	103 @ 14V @ 2ft	5 ~ 14	See Figure	9A	P.C. Board - 2 pin - Sealed	(15 mm c/c)
MAS803	C	2.8	105 @ 7V @ 10cm	1.5 ~ 7	See Figure	9A	P.C. Board - 2 pin - Sealed Back	(15 mm c/c)
MAS803S	C	2.8	105 @ 7V @ 10cm	1.5 ~ 7	See Figure	9A	P.C. Board - 2 pin - Sealed	(15 mm c/c)
PK-21N30P	C	3.0	80	1.5 ~ 30	24 x 9.5	1	P.C. Board - 2 pin	(15 mm c/c)
PK-21N31P	C	3.0	80	1.5 ~ 30	24 x 14	1	P.C. Board - 2 pin - Sealed Back	(15 mm c/c)
PK-21A29P	C	3.0	85	3 ~ 24	24 x 14	1	P.C. Board - 2 pin	(15 mm c/c)
PK-21A31P	C	3.0	85	3 ~ 24	24 x 14	1	P.C. Board - 2 pin - Sealed Back	(15 mm c/c)
MCP320	C	3.1	74 @ 20V	3 ~ 20	24 x 17.5	1A	P.C. Board - 2 pin - Sealed	(15 mm c/c)
PK-27N35PS	C	3.5	90	3 ~ 28	30 x 16	1	P.C. Board - 2 pin	(15 mm c/c)
PK-27N36PS	C	3.5	90	3 ~ 28	30 x 10	1	P.C. Board - 2 pin	(15 mm c/c)
PK-27A35PS	C	3.5	95	3 ~ 24	30 x 16	1	P.C. Board - 2 pin	(15 mm c/c)
PK-20N38P	C	3.8	85	3 ~ 28	23 x 18	1	P.C. Board - 2 pin	(15 mm c/c)
PK-20A38P	C	3.8	95	3 ~ 24	23 x 18	1	P.C. Board - 2 pin	(15 mm c/c)
PK-12N40P	C	4.1	83 @ 10cm	3 ~ 15	13.8 x 7.5	1	P.C. Board - 2 pin	(7.6 mm c/c)
PK-12N40PE	C	4.1	83 @ 10cm	3 ~ 15	13.8 x 7.5	1A	P.C. Board - 2 pin - Sealed	(7.6 mm c/c)
PFD-35N29W	C/FP	2.9	90	3 ~ 28	42 x 16	2	Flange Mount (50 c/c) - 3 wire	
PFD-35A29W	C/FP	2.9	95	3 ~ 24	42 x 16	2	Flange Mount (50 c/c) - 3 wire	
PFD-21N30W	C/FP	3.0	80	3 ~ 30	24 x 9.5	2	Flange Mount (29 c/c) - 3 wire	
PFD-21A29W	C/FP	3.0	85	3 ~ 24	24 x 13.5	2	Flange Mount (28.4 c/c) - 3 wire	
PFD-27N36W	C/FP	3.5	90	3 ~ 28	30 x 10	2	Flange Mount (39 c/c) - 3 wire	
PFD-27N35W	C/FP	3.5	90	3 ~ 28	30 x 16	2	Flange Mount (39 c/c) - 3 wire	
PFD-27A35W	C/FP	3.5	95	3 ~ 24	30 x 16	2	Flange Mount (39 c/c) - 3 wire	
PFD-27N35EP	C/FP	3.5	90	3 ~ 28	See Figure	8	Panel Mount - Tamper Proof	
PFD-27N35ER	C/FP	3.5	90	3 ~ 28	See Figure	8	Panel Mount - Tamper Proof	
PFD-27A35EP	C/FP	3.5	95	3 ~ 24	See Figure	8	Panel Mount - Tamper Proof	
PFD-27A35ER	C/FP	3.5	95	3 ~ 24	See Figure	8	Panel Mount - Tamper Proof	
PFD-20A35EW	C/FP	3.5	95	3 ~ 24	See Figure	7	Panel or Flange Mount - 3 wire	
PFD-21N30P	C/FP	3.0	80	3 ~ 30	24 x 9.5	1	P.C. Board - 3 pin	P2 (7.5mm), P3 (7.5mm)
PFD-27N35P	C/FP	3.5	90	3 ~ 28	30 x 16	1	P.C. Board - 3 pin	P2 (7mm), P3 (11mm)
PFD-27N36P	C/FP	3.5	90	3 ~ 28	30 x 10	1	P.C. Board - 3 pin	P2 (7mm), P3 (11mm)
PFD-27A35P	C/FP	3.5	95	3 ~ 24	30 x 16	1	P.C. Board - 3 pin	P2 (7mm), P3 (11mm)
PLD-35N29W	C/SP	2.9	90	3 ~ 28	42 x 16	2	Flange Mount (50 c/c) - 3 wire	
PLD-35A29W	C/SP	2.9	95	3 ~ 24	42 x 16	2	Flange Mount (50 c/c) - 3 wire	
PLD-21N30W	C/SP	3.0	80	3 ~ 30	24 x 9.5	2	Flange Mount (29 c/c) - 3 wire	
PLD-21A29W	C/SP	3.0	85	3 ~ 24	24 x 13.5	2	Flange Mount (28.4 c/c) - 3 wire	
PLD-27N36W	C/SP	3.5	90	3 ~ 28	30 x 10	2	Flange Mount (39 c/c) - 3 wire	
PLD-27N35W	C/SP	3.5	90	3 ~ 28	30 x 16	2	Flange Mount (39 c/c) - 3 wire	
PLD-27A35W	C/SP	3.5	95	3 ~ 24	30 x 16	2	Flange Mount (39 c/c) - 3 wire	
PLD-27N35EP	C/SP	3.5	90	3 ~ 28	See Figure	8	Panel Mount - Tamper Proof	
PLD-27N35ER	C/SP	3.5	90	3 ~ 28	See Figure	8	Panel Mount - Tamper Proof	
PLD-27A35EP	C/SP	3.5	95	3 ~ 24	See Figure	8	Panel Mount - Tamper Proof	

'C' = Constant, 'FP' = Fast Pulse, 'SP' = Slow Pulse

Piezo Indicators

Catalog Number	Tone	Oscillating Frequency (kHz ± 0.5)	dB (Min) @ 12V @ 30cm	Operating Voltage (VDC)	D x H (mm)	Figure	Mounting & Features	Pitch
PLD-27A35ER	C/SP	3.5	95	3 ~ 24	See Figure	8	Panel Mount - Tamper Proof	P2 (7.5mm), P3 (7.5mm) P2 (7mm), P3 (11mm) P2 (7mm), P3 (11mm) P2 (7mm), P3 (11mm)
PLD-20A35EW	C/SP	3.5	95	3 ~ 24	See Figure	7	Panel or Flange Mount - 3 wire	
PLD-21N30P	C/SP	3.0	80	3 ~ 30	24 x 9.5	1	P.C. Board - 3 pin	
PLD-27N35P	C/SP	3.5	90	3 ~ 28	30 x 16	1	P.C. Board - 3 pin	
PLD-27N36P	C/SP	3.5	90	3 ~ 28	30 x 10	1	P.C. Board - 3 pin	
PLD-27A35P	C/SP	3.5	95	3 ~ 24	30 x 16	1	P.C. Board - 3 pin	
PF-21A29W	FP	3.0	85	3 ~ 24	24 x 13.5	2	Flange Mount (28.4 c/c) - 2 wire	(15 mm c/c) (15 mm c/c)
PF-21N30W	FP	3.0	80	3 ~ 30	24 x 9.5	2	Flange Mount (29 c/c) - 2 wire	
PF-27N25W	FP	2.5	90	3 ~ 28	30 x 16	2	Flange Mount (39 c/c) - 2 wire	
PF-27N26W	FP	2.5	90	3 ~ 28	30 x 10	2	Flange Mount (39 c/c) - 2 wire	
PF-27A25W	FP	2.5	95	3 ~ 24	30 x 16	2	Flange Mount (39 c/c) - 2 wire	
PF-27N36W	FP	3.5	90	3 ~ 28	30 x 10	2	Flange Mount (39 c/c) - 2 wire	
PF-27N35W	FP	3.5	95	3 ~ 28	30 x 16	2	Flange Mount (39 c/c) - 2 wire	
PF-27A35W	FP	3.5	95	3 ~ 24	30 x 16	2	Flange Mount (39 c/c) - 2 wire	
PF-35N29W	FP	2.9	90	3 ~ 28	42 x 16	2	Flange Mount (50 c/c) - 2 wire	
PF-35A29W	FP	2.9	95	3 ~ 24	42 x 16	2	Flange Mount (50 c/c) - 2 wire	
PF-27N35EP	FP	3.5	90	3 ~ 28	See Figure	8	Panel Mount - Tamper Proof	
PF-27N35ER	FP	3.5	90	3 ~ 28	See Figure	8	Panel Mount - Tamper Proof	
PF-27A35EP	FP	3.5	95	3 ~ 24	See Figure	8	Panel Mount - Tamper Proof	
PF-27A35ER	FP	3.5	95	3 ~ 24	See Figure	8	Panel Mount - Tamper Proof	
PF-20A35EW	FP	3.5	95	3 ~ 24	See Figure	7	Panel or Flange Mount - 2 wire	
PF-27N25PS	FP	2.5	90	3 ~ 28	30 x 16	1	P.C. Board - 2 pin	
PF-27N26PS	FP	2.5	90	3 ~ 28	30 x 10	1	P.C. Board - 2 pin	
PF-27A25PS	FP	2.5	95	3 ~ 24	30 x 16	1	P.C. Board - 2 pin	
PF-21N30P	FP	3.0	80	3 ~ 30	24 x 9.5	1	P.C. Board - 2 pin	
PF-21N31P	FP	3.0	80	3 ~ 30	24 x 14	1	P.C. Board - 2 pin - Sealed Back	
PF-21A31P	FP	3.0	85	3 ~ 24	24 x 14	1	P.C. Board - 2 pin - Sealed Back	
PF-21A29P	FP	3.0	85	3 ~ 24	24 x 14	1	P.C. Board - 2 pin	
PF-27N35PS	FP	3.5	90	3 ~ 28	30 x 16	1	P.C. Board - 2 pin	
PF-27N36PS	FP	3.5	90	3 ~ 28	30 x 10	1	P.C. Board - 2 pin	
PF-27A35PS	FP	3.5	95	3 ~ 24	30 x 16	1	P.C. Board - 2 pin	
PL-21N30W	SP	3.0	80	3 ~ 30	24 x 9.5	2	Flange Mount (29 c/c) - 2 wire	
PL-21A29W	SP	3.0	85	3 ~ 24	24 x 13.5	2	Flange Mount (29 c/c) - 2 wire	
PL-27N25W	SP	2.5	90	3 ~ 28	30 x 16	2	Flange Mount (39 c/c) - 2 wire	
PL-27N26W	SP	2.5	90	3 ~ 28	30 x 10	2	Flange Mount (39 c/c) - 2 wire	
PL-27A25W	SP	2.5	95	3 ~ 24	30 x 16	2	Flange Mount (39 c/c) - 2 wire	
PL-27N35W	SP	3.5	90	3 ~ 28	30 x 16	2	Flange Mount (39 c/c) - 2 wire	
PL-27N36W	SP	3.5	90	3 ~ 28	30 x 10	2	Flange Mount (39 c/c) - 2 wire	
PL-27A35W	SP	3.5	95	3 ~ 24	30 x 16	2	Flange Mount (39 c/c) - 2 wire	
PL-35N29W	SP	2.9	90	3 ~ 28	42 x 16	2	Flange Mount (50 c/c) - 2 wire	
PL-35A29W	SP	2.9	95	3 ~ 24	42 x 16	2	Flange Mount (50 c/c) - 2 wire	
PL-27N35EP	SP	3.5	90	3 ~ 28	See Figure	8	Panel Mount - Tamper Proof	
PL-27N35ER	SP	3.5	90	3 ~ 28	See Figure	8	Panel Mount - Tamper Proof	
PL-27A35EP	SP	3.5	95	3 ~ 24	See Figure	8	Panel Mount - Tamper Proof	
PL-27A35ER	SP	3.5	95	3 ~ 24	See Figure	8	Panel Mount - Tamper Proof	
PL-20A35EW	SP	3.5	95	3 ~ 24	See Figure	7	Panel or Flange Mount - 2 wire	
PL-27N25PS	SP	2.5	90	3 ~ 28	30 x 16	1	P.C. Board - 2 pin	
PL-27N26PS	SP	2.5	90	3 ~ 28	30 x 10	1	P.C. Board - 2 pin	
PL-27A25PS	SP	2.5	95	3 ~ 20	30 x 16	1	P.C. Board - 2 pin	
PL-21N30P	SP	3.0	80	3 ~ 28	24 x 9.5	1	P.C. Board - 2 pin	
PL-21A29P	SP	3.0	85	3 ~ 24	24 x 14	1	P.C. Board - 2 pin	
PL-21N31P	SP	3.0	80	3 ~ 28	24 x 14	1	P.C. Board - 2 pin - Sealed Back	
PL-21A31P	SP	3.0	85	3 ~ 24	24 x 14	1	P.C. Board - 2 pin - Sealed Back	
PL-27A35PS	SP	3.5	95	3 ~ 24	30 x 16	1	P.C. Board - 2 pin	
PL-27N35PS	SP	3.5	90	3 ~ 28	30 x 16	1	P.C. Board - 2 pin	
PL-27N36PS	SP	3.5	90	3 ~ 28	30 x 10	1	P.C. Board - 2 pin	

'C' = Constant, 'FP' = Fast Pulse, 'SP' = Slow Pulse

Electro- Magnetic Indicators

Bold-face items are surface mount devices

Catalog Number	Tone	Oscillating Frequency (kHz ± 0.5)	dB (Min) @ 10cm	Operating Voltage (VDC)	D x H (mm)	Figure	Mounting & Features	Pitch
PB-09N23P-01	C	2,300 ± 300	75 @ 1.5V	1.25 ~ 2.5	9 x 5.5	1	P.C. Board - 2 pin	(4 mm c/c)
PB-09N23P-03	C	2,300 ± 300	82 @ 3V	2 ~ 5	9 x 5.5	1	P.C. Board - 2 pin	(4 mm c/c)
PB-12N23P-01	C	2,300 ± 400	80 @ 1.5V	1.25~ 2.5	12 x 10	1A	P.C. Board - 2 pin - Sealed	(7.6 mm c/c)
PB-12N23P-03	C	2,300 ± 400	85 @ 3V	2 ~ 5	12 x 10	1A	P.C. Board - 2 pin - Sealed	(7.6 mm c/c)
PB-12N23P-05	C	2,300 ± 400	85 @ 5V	4.5 ~ 5.5	12 x 10	1A	P.C. Board - 2 pin - Sealed	(7.6 mm c/c)
PB-12N23P-09	C	2,300 ± 400	85 @ 9V	7 ~ 11	12 x 10	1A	P.C. Board - 2 pin - Sealed	(7.6 mm c/c)
PB-12N23P-12	C	2,300 ± 400	85 @ 12V	9 ~ 15	12 x 10	1A	P.C. Board - 2 pin - Sealed	(7.6 mm c/c)
PK-16N04W-03	C	400 ± 100	82 @ 3V	2 ~ 4	See Figure	13	Electric Buzzer	
PK-16N04W-06	C	400 ± 100	85 @ 6V	4 ~ 8	See Figure	13	Electric Buzzer	
PK-16N04W-12	C	400 ± 100	85 @ 12V	8 ~ 16	See Figure	13	Electric Buzzer	
PK-16N04W-24	C	400 ± 100	85 @ 24V	20 ~ 28	See Figure	13	Electric Buzzer	
* ASI301	C	2,400 ± 300	90 @ 5V	4 ~ 7	See Figure**	16	Surface Mount	** (10 mm height)
* ASI401	C	2,400 ± 300	90 @ 12V	9 ~ 15	See Figure**	16	Surface Mount	** (10 mm height)

* Surface Mount units are available taped & reeled by special order - Add TR to part number (ASI301TR)

'C' = Constant, 'FP' = Fast Pulse, 'SP' = Slow Pulse

Piezo Sirens

Catalog Number	Tone	Oscillating Frequency (kHz)	dB (Min) @ 12V @ 100cm	Operating Voltage (VDC)	Sweep	Figure	Description
PS-580	Constant	2.8 ± 0.5	100	5 ~ 15	-	22	Piezo Siren
PS-500	Constant	2.8 ± 0.5	105	5 ~ 15	-	25	Piezo Siren
PS-530	Constant	2.8 ± 0.5	105	5 ~ 15	-	19	Piezo Siren
PS-550	Constant	2.8 ± 0.5	105	5 ~ 15	-	20	Piezo Siren
PS-570	Constant	2.8 ± 0.5	105	5 ~ 15	-	28	Piezo Siren
PS-520	Constant	3.0 ± 0.5	105	5 ~ 15	-	18	Piezo Siren
PS-510	Constant	3.0 ± 0.5	108	5 ~ 15	-	26	Piezo Siren
PS-531	Pulse	2.8 ± 0.5	105	5 ~ 15	1.2	19	Piezo Siren
PS-551	Pulse	2.8 ± 0.5	105	5 ~ 15	1.2	20	Piezo Siren
PS-571	Pulse	2.8 ± 0.5	105	5 ~ 15	1.2	28	Piezo Siren
PS-501	Pulse	2.8 ± 0.5	105	5 ~ 15	1.2	25	Piezo Siren
PS-521	Pulse	3.0 ± 0.5	105	5 ~ 15	1.2	18	Piezo Siren
PS-511	Pulse	3.0 ± 0.5	108	5 ~ 15	1.2	26	Piezo Siren
PS-562	Hi-Lo	2.5 / 3.5	100	5 ~ 15	1.2	21	Piezo Siren
PS-552	Hi-Lo	2.5 / 3.5	105	5 ~ 15	1.2	20	Piezo Siren
PS-522	Hi-Lo	2.5 / 3.5	105	5 ~ 15	1.2	18	Piezo Siren
PS-572	Hi-Lo	2.5 / 3.5	105	5 ~ 15	1.2	28	Piezo Siren
PS-502	Hi-Lo	2.5 / 3.5	105	5 ~ 15	1.2	25	Piezo Siren
PS-532	Hi-Lo	2.3 / 3.5	105	7 ~ 15	1.2	19	Piezo Siren
PS-512	Hi-Lo	2.5 / 3.5	108	5 ~ 15	1.2	26	Piezo Siren
PS-583	Sweep	1.5 - 3.5	105	5 ~ 15	3.3	22	Piezo Siren
PS-533	Sweep	1.5 - 3.5	105	5 ~ 15	3.3	19	Piezo Siren
PS-553	Sweep	1.5 - 3.5	105	5 ~ 15	4.5	20	Piezo Siren
PS-573	Sweep	1.5 - 3.5	105	5 ~ 15	3.3	28	Piezo Siren
PS-503	Sweep	1.5 - 3.5	105	5 ~ 15	3.3	25	Piezo Siren
PS-983	Sweep	1.5 - 3.5	105	5 ~ 15	3.3	34	Piezo Siren
PS-953	Sweep	1.5 - 3.5	105	5 ~ 15	3.3	33	Piezo Siren
PS-723A	Sweep	1.5 - 3.5	105	5 ~ 15	3.3	32	Piezo Siren
PS-713	Sweep	1.5 - 3.5	105	5 ~ 15	3.3	31	Piezo Siren
PS-393	Sweep	1.5 - 3.5	108	5 ~ 15	3.3	27	Piezo Siren
PS-513	Sweep	1.5 - 3.5	110	5 ~ 15	3.3	26	Piezo Siren
PS-593	Sweep	1.5 - 3.5	115	5 ~ 15	3.3	23	Piezo Siren
PS-593L	Sweep	1.5 - 3.5	115	5 ~ 15	3.3	24	Piezo Siren
PS-523A	Sweep	1.5 - 4.0	105	5 ~ 15	4.5	18	Piezo Siren
PS-913	Sweep + Red Light	1.5 - 3.5	105	5 ~ 15	3.3	30	Intruder Alarm with Strobe & Siren
PS-903	Sweep + Red Light	2.4 - 3.7	105	5 ~ 15	3.3	29	Intruder Alarm with Strobe & Siren

